

Hood County Regional Sewerage System

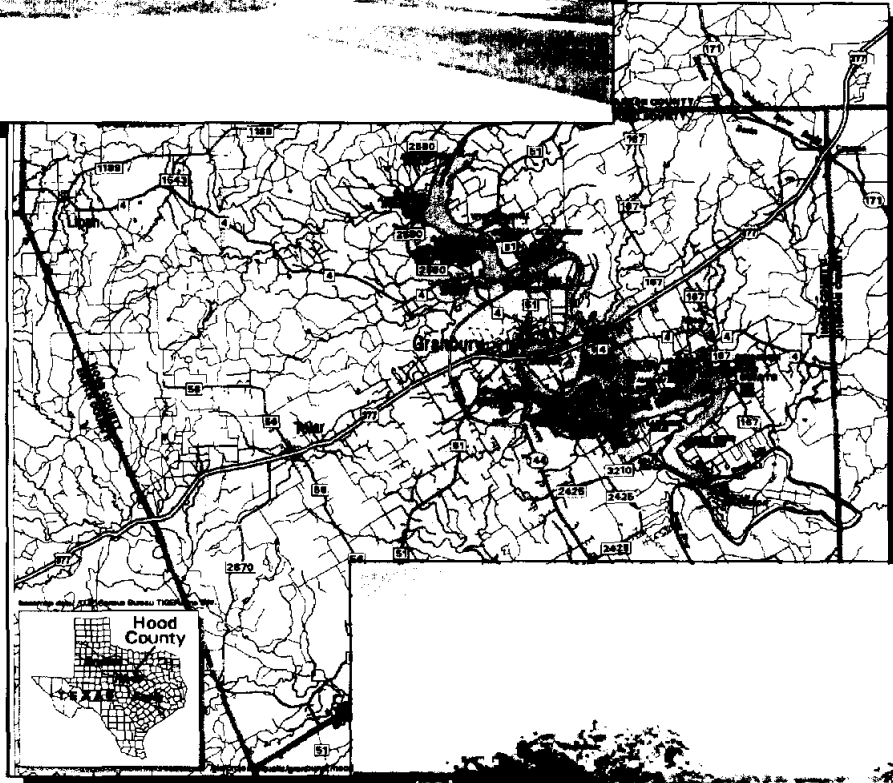

RECEIVED
DEC 13 2000
TWIDE RIVER
COMMITTEE

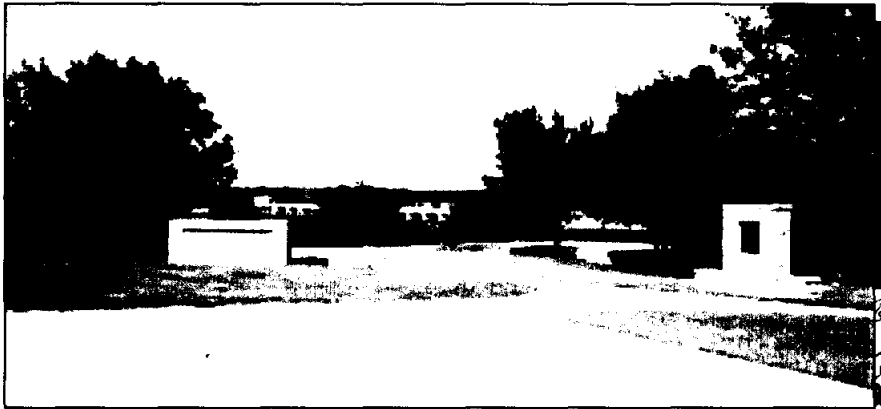

Brazos River Authority

&

Hood County
Intergovernmental
Committee

November 2000



Hood County Regional Sewerage System Feasibility Study

**Prepared for
Hood County Intergovernmental Committee
and
Brazos River Authority**

Prepared by



November 2000



Signature Sheet

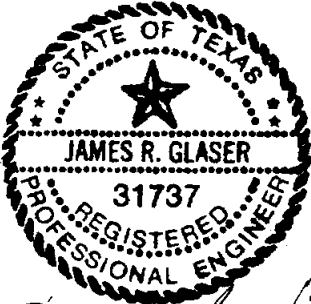

James R. Glaser
11/24/00

James R. Glaser, P.E.
HDR Engineering, Inc.

Table of Contents

<u>Section</u>	<u>Page</u>
Executive Summary	ix
1 Introduction	1-1
1.1 General	1-1
1.2 Study Area.....	1-1
1.3 Scope	1-5
2 Population and Wastewater Flow Projections	2-1
2.1 Planning Basis	2-1
2.2 Population Forecasts	2-1
2.3 Wastewater Flows	2-8
2.3.1 Existing Wastewater Flows.....	2-8
2.3.2 Projected Wastewater Flows	2-13
3 Existing Wastewater Facilities	3-1
3.1 General	3-1
3.2 Wastewater Collection Systems	3-5
3.3 Existing Wastewater Treatment Plants	3-5
3.3.1 City of Granbury Southeast Wastewater Treatment Plant	3-5
3.3.2 Acton MUD – DeCordova Bend Wastewater Treatment Plant	3-9
3.3.3 Acton MUD – Pecan Plantation Wastewater Treatment Plant	3-11
3.3.4 City of Tolar Wastewater Treatment Plant	3-12
3.3.5 City of Lipan Wastewater Treatment Plant.....	3-13
3.3.6 Summary	3-13
4 Water Quality and Wastewater Treatment Requirements	4-1
4.1 General	4-1
4.1.1 Water Quality	4-1
4.1.2 Wastewater Treatment Requirements — General.....	4-1
4.2 Wastewater Discharge Requirements.....	4-2
4.2.1 Plants Discharging to a Receiving Water.....	4-2
4.2.2 No-Discharge Systems	4-3

Table of Contents (continued)

<u>Section</u>	<u>Page</u>
4.3	Use of Reclaimed Water 4-6
4.4	Summary 4-12
5	Wastewater Alternatives 5-1
5.1	General 5-1
5.2	Wastewater Treatment and Collection System Alternatives..... 5-2
5.2.1	Alternative 1 – City of Granbury Wastewater Treatment Plant plus Four Others 5-15
5.2.2	Alternative 2 – City of Granbury Wastewater Treatment Plant plus Three Others..... 5-15
5.2.3	Alternative 3 – City of Granbury Wastewater Treatment Plant plus Two Others..... 5-15
5.2.4	Alternative 4 – City of Granbury Wastewater Treatment Plant plus One Other..... 5-15
5.2.5	Alternative 5 – City of Granbury Wastewater Treatment Plant plus Two Others..... 5-16
5.2.6	Alternative 6 – City of Granbury Wastewater Treatment Plant plus Two Others..... 5-16
5.3	Estimated Costs of Alternatives 5-17
5.3.1	Capital Costs 5-18
5.3.2	Operation and Maintenance Costs..... 5-20
5.4	Collection in Existing Developed Areas 5-23
5.4.1	Estimation of Sewer Service Type..... 5-23
5.4.2	Estimation of Sewer Lengths 5-27
5.4.3	Estimation of Sewer System Cost..... 5-27
6	Institutional and Financing Options for Ownership and Operations..... 6-1
6.1	Continuation of Separate Ownership and Operations (Status Quo)..... 6-2
6.2	Alternative Regional Arrangements..... 6-5
6.2.1	Separate Ownership and Regional Operations..... 6-5
6.2.2	Regional Ownership and Operations..... 6-7
6.3	Institutional Conclusions..... 6-11

**Table of Contents
(continued)**

<u>Section</u>	<u>Page</u>
6.4 Alternative Sources of Financing	6-12
6.4.1 Open Market Bonds	6-14
6.4.2 Texas Water Development Board Programs	6-14
6.4.3 Federal Grants	6-16
7 Implementation Plan	7-1
7.1 General	7-1
7.2 Organization	7-1
7.3 Funding and Financing	7-1
7.4 Regional Wastewater Collection and Treatment Facilities	7-5

Appendices

Appendix A	Alternative 6 Costs
Appendix B	Cost Breakdown to Provide Sewerage Service for Existing Developed Areas
Appendix C	Texas Water Development Board Comments on Draft Report

(This page is intentionally left blank.)

List of Figures

<u>Figure</u>		<u>Page</u>
ES-1	Projected Population	xii
ES-2	Average Daily Wastewater During Peak Month SB1 Forecast	xiv
ES-3	Average Daily Flow During the Peak Month Hood County High Case Population	xv
ES-4	Alternative 6 (Plants and Collection)	xxi
ES-5	Alternate 6 (Phasing Plan).....	xxiii
ES-6	Simplified Schematic Implementation Plan for Regional Wastewater System.....	xxv
1-1	Location/Area Map	1-3
2-1	Projected Population	2-2
2-2	Projected Hood County Urban and Rural Population (SB1 Forecast).....	2-6
2-3	Projected Hood County “County Other” Population (SB1 Forecast).....	2-7
2-4	City of Granbury Wastewater Flows.....	2-11
2-5	Acton MUD DeCordova Bend Wastewater Flows	2-12
2-6	Acton MUD Pecan Plantation Wastewater Flows	2-12
2-7	Average Annual Daily Wastewater Flows — Hood County SB1 Population.....	2-17
2-8	Average Annual Daily Wastewater Flows — Hood County High Case Population.....	2-19
2-9	Average Daily Flow During the Peak Month — Hood County SB1 Population.....	2-21
2-10	Average Daily Flow During the Peak Month — Hood County High Case Population.....	2-22

**List of Figures
(continued)**

<u>Figure</u>		<u>Page</u>
2-11	Peak Instantaneous Wastewater Flow — Hood County SB1 Population.....	2-25
2-12	Peak Instantaneous Wastewater Flows — Hood County High Case Population.....	2-27
2-13	Location of Areas with Significant Wastewater Flows.....	2-29
3-1	Existing Wastewater Treatment Facilities.....	3-3
3-2	Location of Sewered and Unsewered Developed Areas	3-7
3-3	Schematic — City of Granbury WWTP	3-10
3-4	Schematic of DeCordova Bend Wastewater Treatment Plant	3-11
3-5	Schematic of Pecan Plantation Wastewater Treatment Plant.....	3-11
3-6	Schematic of City of Tolar's Wastewater Treatment Plant	3-12
3-7	Schematic of City of Lipan's Wastewater Treatment Plant	3-13
4-1	Conceptual Schematic / Ultimate Wastewater Treatment Facilities.....	4-5
4-2	Golf Course and Proposed Power Plant Location.....	4-9
5-1	Alternative 1 (Plants and Collection).....	5-3
5-2	Alternative 2 (Plants and Collection).....	5-5
5-3	Alternative 3 (Plants and Collection).....	5-7
5-4	Alternative 4 (Plants and Collection).....	5-9
5-5	Alternative 5 (Plants and Collection).....	5-11
5-6	Alternative 6 (Plants and Collection).....	5-13
5-7	Alternative 6 (Phasing Plan)	5-21
5-8	Gravity and Pressure Sewer Areas	5-25
7-1	Simplified Schematic Implementation Plan for Regional Wastewater System.....	7-3

List of Tables

<u>Table</u>	<u>Page</u>
ES-1 Wastewater Flows Important to Planning and Design	xii
ES-2 Unit Wastewater Flows Used in Study	xiii
ES-3 Existing or Permitted Wastewater Treatment Facilities Hood County Regional Wastewater System Feasibility Study	xvi
ES-4 Estimated Costs — Alternative 6	xvi
ES-5 Costs by Stage for Stages Implementation of Alternate 6	xxii
2-1 Hood County Population Based on SB1 Forecasts	2-2
2-2 Hood County Population Based on High Growth Forecasts	2-4
2-3 Granbury Daily Wastewater Inflow (MGD)	2-9
2-4 Acton MUD Wastewater Inflow	2-10
2-5 Average Daily Wastewater Flows with SB1 Population	2-16
2-6 Average Daily Wastewater Flows with High Case Population (MGD)	2-18
2-7 Peak Daily Wastewater Flow with SB1 Population (MGD)	2-20
2-8 Average Daily Flow During the Peak Month with High Case Population (MGD)	2-22
2-9 Peak Instantaneous Wastewater Flows with SB1 Population	2-24
2-10 Peak Instantaneous Wastewater Flows with High Case Population	2-26
3-1 Existing or Permitted Wastewater Treatment Facilities Hood County Regional Wastewater System Feasibility Study	3-1
3-2 Existing or Permitted Wastewater Treatment Facilities Hood County Regional Wastewater System Feasibility Study	3-5
4-1 Selected Current and Anticipated Effluent Design Requirements Hood County Regional Wastewater System Feasibility Study	4-4

**List of Tables
(continued)**

<u>Table</u>		<u>Page</u>
4-2	Summary Information — TNRCC Regulations Regarding Use of Treated Wastewater	4-6
4-3	Granbury Area Golf Courses.....	4-11
4-4	TNRCC Chapter 210 Type 1 and Type 2 Quality Requirements Regarding Use of Reclaimed Water.....	4-11
5-1	Treatment Plant Scenarios for all Alternatives	5-17
5-2	Easement and Land Costs	5-18
5-3	Construction Costs	5-19
5-4	Summary of Capital Costs.....	5-20
5-5	Annual O&M Costs.....	5-20
5-6	Total Annual Costs.....	5-23
5-7	Sewer Service Criteria.....	5-24
5-8	Sewer Line Lengths.....	5-27
5-9	Cost Data.....	5-28
5-10	Summary of Totals	5-28
5-11	Total Cost.....	5-28
6-1	Comparison of Alternative of Institutional Approaches to Wastewater Utility Service.....	6-3
6-2	Amount of Cash-Funded Capital Project Support with Alternative Impact Fees and New Connections	6-9
6-3	Amount of Debt-Funded Capital that could be Supported with Alternative Tax Rates and Tax Bases	6-9
6-4	Funding and Regulatory Capabilities of Potential Regional Entities with Specific Legal Authority.....	6-13

Executive Summary

ES.1 Introduction

Hood County has experienced rapid growth in recent years, and much of the growth has occurred in areas that do not have wastewater collection systems and that rely on on-site wastewater systems. Soil conditions in much of the County are not ideal for on-site wastewater systems, and continuing growth in the area coupled with concerns regarding the potential impacts of on-site systems on water quality led to the initiation of this regional sewerage system feasibility study.

The study area included Hood County. Study sponsors are the City of Granbury, the City of Lipan, the City of Tolar, Acton Municipal Utility District (MUD), Hood County, and the Brazos River Authority. A portion of the study funding was provided by the Texas Water Development Board (TWDB).

General objectives of the study are summarized as:

1. Develop population and wastewater flow projections for the study area;
2. Inventory and evaluate existing wastewater facilities in the study area;
3. Identify collection system alternatives to provide a regional system to serve the study area;
4. Identify wastewater treatment alternatives to serve the study area;
5. Identify organizational structures appropriate for administration, management, and operation of a regional system;
6. Develop estimated capital and annual costs associated with implementation of a regional sewerage system; and
7. Develop recommendations for a regional system.

ES.2 Population and Wastewater Flow Projections

Projections of the population that is to be served provide the basis for establishing facility needs for both water and wastewater planning studies. In wastewater planning studies, projected populations are used in conjunction with estimated flows per person (gallons per capita per day) to estimate the flows to be handled.

The TWDB has prepared population projections for Hood County (and all counties in Texas) as part of their Senate Bill 1 (SB1) planning efforts. Input from study area participants indicated that a growth scenario that is higher than the TWDB population projections should be included in the study, and the study thus includes two population projections, one based on

TWDB SB1 population projections, and a higher population projection based on local input. Projected populations based on both the TWDB SB1 projections and on local input are shown graphically in Figure ES-1.

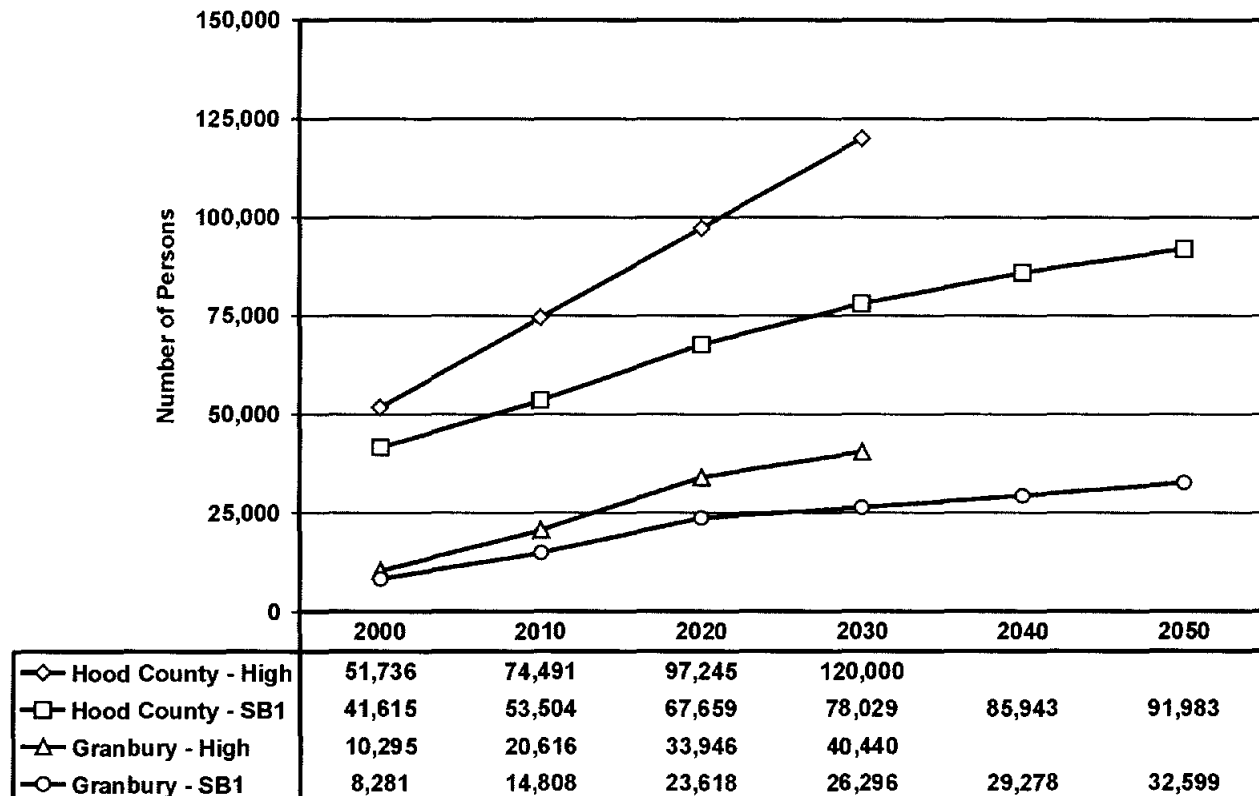

Figure ES-1. Projected Population

Figure ES-1 indicates projected populations for Hood County, which includes the City of Granbury, and for the City of Granbury alone. The projections denoted as “High” are based on local input, while those denoted as SB1 are based on TWDB projections. The year 2030 population projections for Hood County based on TWDB projections and local input are 78,029 and 120,000, respectively.

Past wastewater flow data and estimates of past populations for the City of Granbury and Acton MUD were used to develop estimated unit flows. The estimated unit flows were then used with projected populations to develop projections of future wastewater flows in the County.

Peak instantaneous flow, average flow, and average daily flow during the peak month are important in wastewater planning and design, and their significance is described in Table ES-1. The basis for calculating the flows for different areas in the County is listed in Table ES-2.

**Table ES-1.
Wastewater Flows Important to Planning and Design**

Flow	Description and Comments
Average Annual Daily Flow	<ul style="list-style-type: none"> • Used as a basis of estimating other flows listed below. • Serves as a basis for estimating annual operation and maintenance costs for wastewater facilities.
Average Daily Flow During the Peak Month	<ul style="list-style-type: none"> • Used to determine the required TNRCC permitted monthly flow of wastewater treatment facilities. • One parameter used to establish the size of treatment unit components.
Peak Instantaneous Flow	<ul style="list-style-type: none"> • Used to determine the required capacity of all conveyance facilities (pipelines and lift stations). • One parameter used to establish the size of wastewater treatment units. • Along with the average daily flow during the peak month, the peak instantaneous flow is normally listed in the TNRCC permit (as the peak 2-hour flow).

**Table ES-2.
Unit Wastewater Flows Used In Study**

Area	Basis of Flow
City of Granbury	<ul style="list-style-type: none"> • Average Annual Daily Flow – 140 gpcd based on historical data. • Average Daily Flow During the Peak Month – 1.25 times average annual daily flow, slightly higher than historical data. • Peak Instantaneous – 4 times average annual daily flow based on ratio considered appropriate based on consultant past experience.
Acton MUD	<ul style="list-style-type: none"> • Average Annual Daily Flow – 90 gpcd based on historical data. • Average Daily Flow During the Peak Month – 1.8 times average annual daily flow based on historical data. • Peak Instantaneous – 4 times average annual daily flow based on ratio considered appropriate based on consultant past experience.
Other Entities and Areas	<ul style="list-style-type: none"> • Average Annual Daily Flow – 100 gpcd based on TNRCC default value. • Average Daily Flow During the Peak Month – 1.3 times average annual daily flow based on consultant past experience. • Peak Instantaneous – 4 times average annual daily flow based on ratio considered appropriate based on consultant past experience.

Detailed information concerning wastewater flow projections is presented in the report. Projected average daily wastewater flows during the peak month are used in determining the capacity of treatment plants. Projected average daily wastewater flows during the peak month based on TWDB SB 1 and high growth population projections are shown in Figures ES-2 and ES-3, respectively. The TWDB SB 1 projections indicate that the average daily flow during the peak month will increase from approximately 5.46 million gallons per day (MGD) in year 2000 to approximately 10.8 MGD in year 2030, and the high growth population projections indicate that the flow will increase to approximately 16.7 MGD in year 2030.

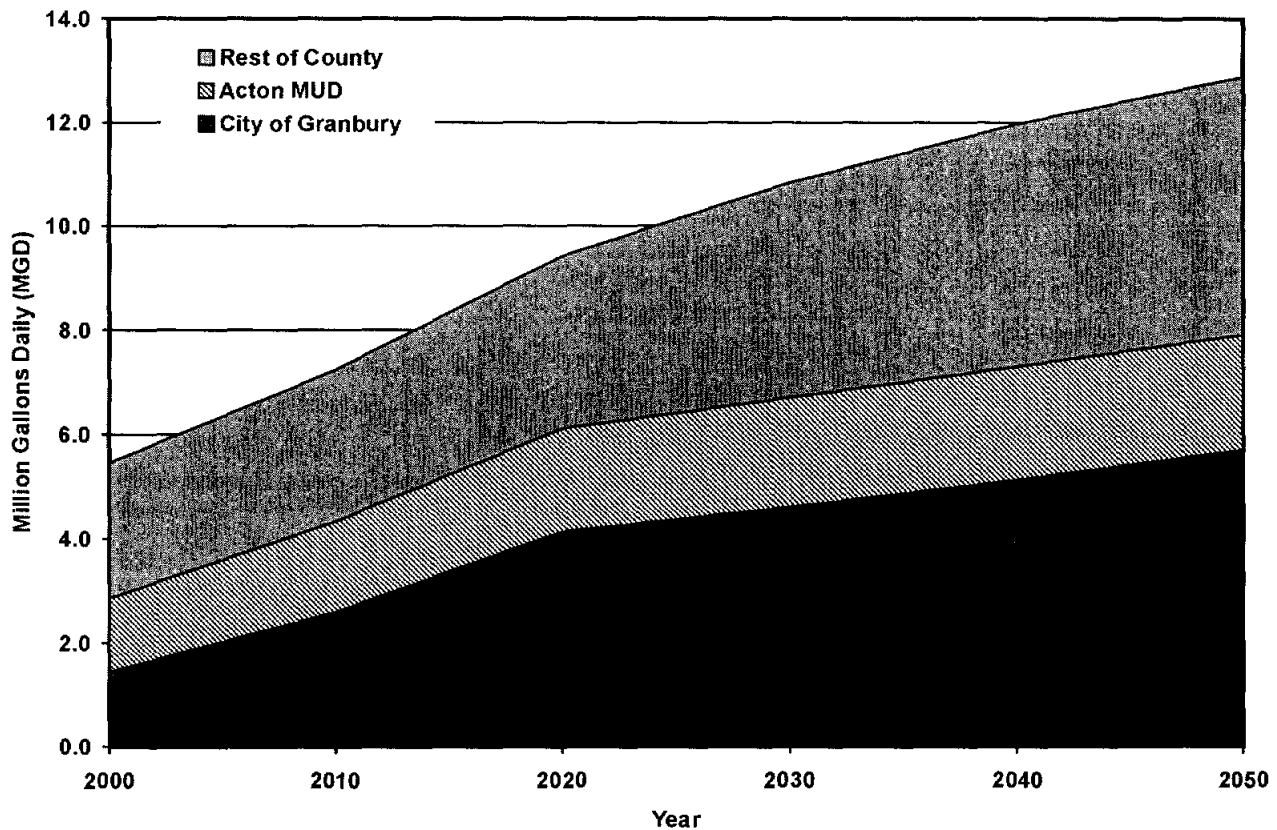
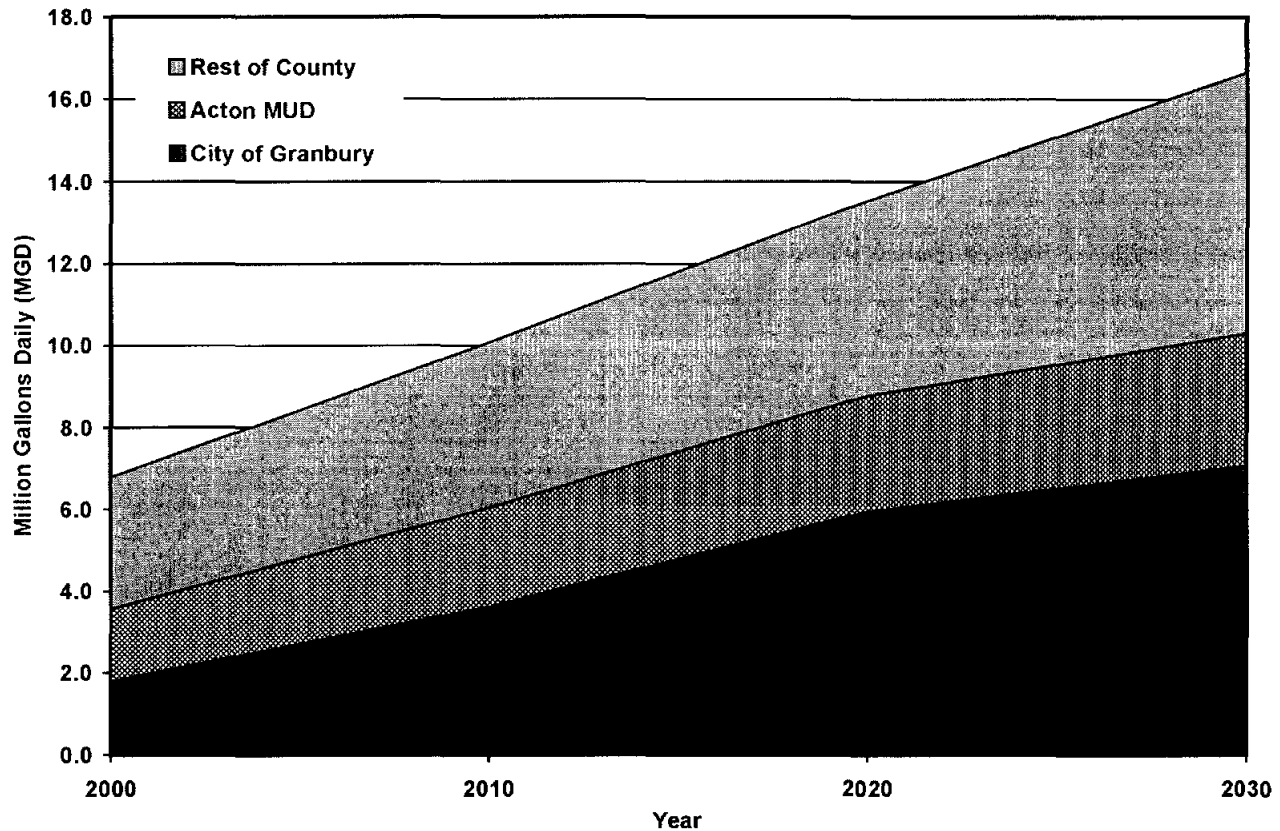

Figure ES-2. Average Daily Wastewater During Peak Month SB1 Forecast

ES.3 Existing Wastewater Facilities

Available information concerning existing wastewater facilities in Hood County is listed in Table ES-3. The total currently permitted flow is approximately 2.8 MGD and will increase to



**Figure ES-3. Average Daily Flow During the Peak Month
Hood County High Case Population**

approximately 3.1 MGD when expansions at the Acton MUD plants are completed. As indicated in the preceding paragraph, projected average daily wastewater flows during the peak month are expected to increase to approximately 10.8 MGD by 2030 based on TWDB SB 1 population projections, and to approximately 16.7 MGD based on the high growth population projections. Considerable increase in treatment capacity and attendant collection system capacity will be needed to provide collection systems and treatment capacity for the existing population and for projected growth.

ES.4 Alternatives

Six alternative means of meeting wastewater needs were evaluated. Assumptions that were common to all alternatives are listed below.

- The City of Granbury Wastewater Treatment Plant (WWTP) will continue in service at the permitted capacity of 2 MGD.

**Table ES-3.
Existing or Permitted Wastewater Treatment Facilities
Hood County Regional Wastewater System Feasibility Study**

Owner and/or Facility	Permit Parameters			
	Monthly Flow (MGD)	CBOD (mg/L)	TSS (mg/L)	NH ₃ (mg/L)
City of Granbury, Southeast WWTP ¹	2	10	15	3
Acton MUD, DeCordova Bend ²	0.24	10	15	3
City of Tolar	0.10	10	15	3
Acton MUD, Pecan Plantation ³	0.24	10	15	3
Hood County Utilities, Inc.	0.088	10	15	NA
City of Lipan	0.10	30	90	NA
Fall Creek Utility	Information not obtained			
¹ Plant expansion is currently underway. ² Plant is to be expanded to 0.375 MGD. Construction project underway at plant. ³ Plant is to be expanded to 0.39 MGD.				

- The Acton MUD wastewater treatment plants will be phased out over time, due to site constraints and age of the facilities. The Acton MUD wastewater treatment plant sites will serve as lift station sites when the plants are phased out, and the phase-out schedule for the plants will be dictated by economics.
- Development in the area around the City of Tolar (within 1-1/2 miles plus or minus) will be served at the City of Tolar WWTP site.
- Development in the area of Lipan (within 1-1/2 miles plus or minus) will be served at the City of Lipan WWTP site.
- Existing developed areas without sewer service around Lake Granbury and the high population growth forecast for the areas adjacent to the proposed northwest loop around Granbury, near the area around the intersection of Highways 144 and 377, along Highway 377 east of Granbury, and around Acton MUD will be served by either the existing City of Granbury plant or by new treatment facilities.

Based on the planning assumptions above, the area around the City of Granbury and Acton MUD was divided into four service areas, and the six alternative treatment and associated collection options were developed to serve existing areas without sewer service and the high growth areas.

The six treatment and collection alternatives are described in detail in the report, and major facilities included in each alternative are shown in Figures in the report. Summary information concerning the options is listed below.

- Alternative 1. The existing City of Granbury WWTP plus plants in each of the four service areas.

- Alternative 2. The existing City of Granbury WWTP plus plants in three of the four service areas (northwest, southeast, and south).
- Alternative 3. The existing City of Granbury WWTP plus plants in two of the four service areas (southeast and south).
- Alternative 4. The existing City of Granbury WWTP plus plants in one of the four service areas (south).
- Alternative 5. The existing City of Granbury WWTP plus plants in two of the four service areas (northwest and south). Alternative 5 differs from Alternative 3 in plant location.
- Alternative 6. The existing City of Granbury WWTP plus plants in two of the four service areas (northwest and south). Alternative 6 differs from Alternative 5 in that Alternative 5 included lift station and plant capacities based on high population growth flow projections, and Alternative 6 included lift station and treatment capacities based on TWDB SB 1 capacities. Initially, Alternatives 1 through 5 were considered. Alternative 6 was added to reduce implementation costs without compromising future flexibility.

Other comments concerning the alternatives are listed below.

- Alternatives 1 through 5 are all based on lift station and treatment capacities developed using the high population growth projections.
- Alternative 6 is based on lift station and treatment capacities developed using TWDB SB 1 projections, but land costs included in the estimated costs for Alternative 6 are based on providing adequate land for facilities needed to meet the high growth needs.
- Land costs in all cases are based on 500 feet buffers around treatment facilities.
- Land allocated for treatment facilities allows space for upgrading facilities to meet more stringent effluent parameters than are currently applicable to plants in Hood County.
- Local entities are aware that funding through any TWDB-administered programs will require justification if facilities are sized to provide capacity in excess of capacity required based on TWDB population projections, or that the excess capacity will have to be funded entirely by local sources.

Detailed estimated costs for all alternatives are presented in the report and appendices. Estimated costs of the alternatives are summarized in Table ES-4. The costs include costs associated with providing collection systems in currently developed areas.

Alternative 6 results in the lowest capital and annual costs of the 5 alternatives. Lift station and treatment capacities are not as great in Alternative 6 as in the other alternatives, but space allowed in Alternative 6 will allow facilities to be expanded when and as needed. Because of the lower costs associated with Alternative 6, and because implementation of Alternative 6 allows flexibility to expand, it is the alternative recommended for implementation. Major

**Table ES-4.
Estimated Costs—Alternatives 1-6**

Capital Costs	Alternative 1	Alternative 2	Alternative 3	Alternative 4	Alternative 5	Alternative 6
Easement Costs for Pipelines	\$151,000	\$155,000	\$154,000	\$162,000	\$162,000	\$162,000
Lift Station Land Costs	330,000	330,000	330,000	330,000	330,000	330,000
Treatment Plant Land Costs	1,171,000	984,000	797,000	611,000	797,000	797,000
Treatment Plants	53,755,000	53,199,000	49,518,000	40,180,000	49,380,000	26,070,000
Lift Stations	30,011,000	32,988,000	32,988,000	37,780,000	36,961,000	22,770,000
Force Mains	10,931,000	11,469,000	12,289,000	12,210,000	11,896,000	11,896,000
Gravity Interceptors	2,085,000	2,905,000	2,947,000	3,941,000	3,910,000	3,910,000
Collection System	20,896,000	20,896,000	20,896,000	20,896,000	20,896,000	20,896,000
Subtotal Capital Costs	\$119,330,000	\$122,926,000	\$119,919,000	\$116,110,000	\$124,332,000	\$86,831,000
Contingencies (20%)	23,866,000	24,585,200	23,983,800	23,222,000	24,866,400	17,366,200
Engineering (15%)	17,899,500	18,438,900	17,987,850	17,416,500	18,649,800	11,288,030
Surveying (5%)	5,966,500	6,146,300	5,995,950	5,805,500	6,216,600	4,341,550
Testing (5%)	5,966,500	6,146,300	5,995,950	5,805,500	6,216,600	4,341,550
Administration (4%)	4,773,200	4,917,040	4,796,760	4,644,400	4,973,280	1,736,620
Resident Project Rep. (5%)	5,966,500	6,146,300	5,995,950	5,805,500	6,216,600	3,473,240
Grand Total Capital Costs	\$183,800,000	\$189,300,000	\$184,700,000	\$178,800,000	\$191,500,000	\$129,400,000
Annual Debt Service, n=20 yrs, i=6%	\$16,025,000	\$16,504,000	\$16,103,000	\$15,589,000	\$16,696,000	\$11,282,000
Annual O&M Costs	Alternativ e 1	Alternativ e 2	Alternativ e 3	Alternativ e 4	Alternativ e 5	Alternativ e 6
Treatment Plants	\$3,525,000	\$3,422,000	\$3,136,000	\$2,756,000	\$3,104,000	\$1,954,000
Sewer Pipelines	608,000	628,000	616,000	610,000	623,000	623,000
Lift Stations	699,000	726,000	735,000	839,000	758,000	591,000
Grand Total Annual O&M Costs	\$4,832,000	\$4,776,000	\$4,487,000	\$4,205,000	\$4,485,000	\$3,168,000
Total Annual Costs	Alternative 1	Alternative 2	Alternative 3	Alternative 4	Alternative 5	Alternative 6
Debt Service	\$16,025,000	\$16,504,000	\$16,103,000	\$15,589,000	\$16,696,000	\$11,282,000
O&M	4,832,000	4,776,000	4,487,000	4,205,000	4,485,000	3,168,000
Grand Total Annual Costs	\$20,857,000	\$21,280,000	\$20,590,000	\$19,794,000	\$21,181,000	\$14,450,000
Notes:						
1. Alternative 6 is based on Alternative 5 with the following differences:						
a. Treatment plant and lift station capital costs are based on SB1 population projections.						
b. Fees for Engineering, Administration, and Resident Project Rep. were reduced to 13%, 2%, and 4%, respectively.						

facilities included in Alternative 6 are shown in Figure ES-4, and a possible staging plan for Alternative 6 is shown in Figure ES-5. A preliminary staging plan is included because implementation costs are high and staging will be required to match costs with funding. The facility locations shown in Figures ES-4 and ES-5 are general only; detailed siting studies will be required to finalize locations.

New development pressure coupled with the implementation cost of a regional system will likely result in a need for some small or package treatment plants to be constructed to serve new development. All plants must be permitted by the Texas Natural Resource Conservation Commission (TNRCC), and interested entities and parties in the area should participate in permit hearings and attempt to have a condition included in TNRCC permits for any proposed plants that will require that the collection system served by the plant be connected to a regional system when a regional system becomes available.

ES.5 Implementation

An organizational structure for a regional sewerage system must be selected and/or established, and a means of financing and funding the system developed. Information regarding possible organizational structures and funding and financing is presented in the report.

Possible organizational structures include separate ownership and control of systems in the area (existing situation), separate ownership of facilities and a regional operator, and regional ownership and operation. Organizational structure of and funding and financing for a regional sewerage system are both complex issues, with overlapping between the two. Potential regional participants should obtain appropriate input from financial advisers and legal counsel in arriving at decisions regarding organizational structure and funding and financing the system.

Ownership and operation of the system could be provided through existing entities such as the City of Granbury, Hood County, Acton MUD, and the Brazos River Authority, or new districts (either taxing or non-taxing) could be established. Because of the implementation costs associated with a regional system, programs such as the State Participation fund, which allows payment for system oversizing to be deferred, development of impact fees, or use of tax funds deserve consideration and evaluation.

A simplified schematic indicating the steps in implementation of a regional system is shown in Figure ES-6. The first key steps are indicated by the two blocks on the left of the

(This page is intentionally left blank.)

1/15. ES-4

Fig ES-5

F ES-6

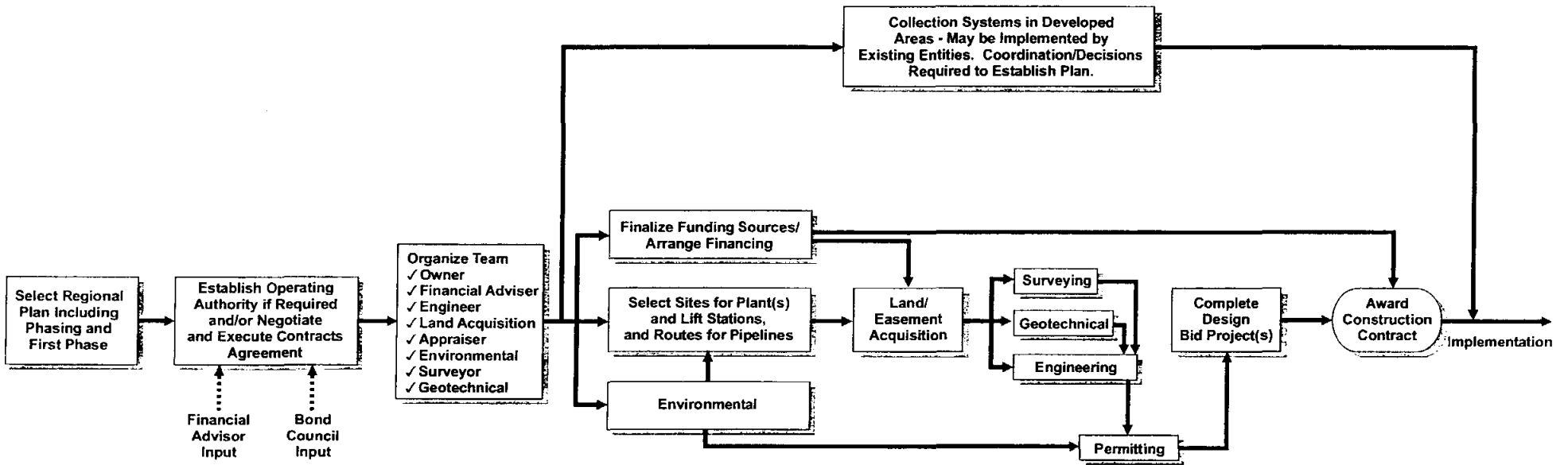

Notes:

1. Multiple construction projects are anticipated for Lines and Lift Stations.
2. Geotechnical work and surveying may be initiated prior to completion of acquisition depending on nature of negotiations.
3. Arrangements can normally be made to conduct surveying and geotechnical work while land acquisition negotiations are in progress.

Figure ES-6. Simplified Schematic Implementation Plan for Regional Wastewater System

schematic, and involve selection of the plan to be implemented and a decision regarding organizational structure, which is tied to financing, so decisions regarding organization and financing must be made prior to firming up later steps shown in the schematic. The steps in the schematic that follow the first two blocks are generic tasks that are generally common to implementation of projects.

Costs of project implementation are high due to the need to construct collection systems in currently developed areas and due to terrain and other area characteristics. Improvements will have to be staged, and development of the staging plan will require careful attention and coordination with financial and environmental issues. One possible staging plan was shown in Figure ES-5, and capital costs for the various stages are shown in Table ES-5. The staging plan shown in Figure ES-5 should be considered as a starting point as it will almost certainly be modified and refined as project implementation plans continue to be developed.

Table ES-5.
Costs by Stage for Stages Implementation of Alternate 6

Cost	Phase (See Figure ES-6 for Facilities)				
	1A	1B	1C	1D	1E
Capital ¹	\$4,210,200	\$20,381,844	\$41,700,740	\$45,519,923	\$17,555,548
Annual Cost ²	\$466,090	\$2,256,790	\$4,617,720	\$5,040,630	\$1,944,370
¹ Capital cost listed includes an allowance for contingencies, engineering, administration and other projects costs similar to cost listed in Table ES-5 for alternatives. ² Annual cost includes debt service for 20 years at 6% and estimated operation and maintenance costs.					

Section 1 Introduction

1.1 General

This study involved evaluating the feasibility of implementing a regional sewerage system for the Hood County area and development of an implementation plan for a regional system if such a system is deemed feasible. The study was initiated due to concerns about existing on-site wastewater systems in the area, the rapid growth in the area and concerns about handling future wastewater flows, and concerns regarding water quality.

The sponsors of this study are the City of Granbury, the City of Lipan, the City of Tolar, Acton Municipal Utility District (MUD), Hood County, and the Brazos River Authority (BRA). A portion of the cost of the study was funded by the Texas Water Development Board (TWDB).

1.2 Study Area

Hood County is located in a scenic area that is readily accessible from the Dallas-Fort Worth metroplex. The location and attractions, including Lake Granbury, of Hood County have resulted in rapid growth and substantial tourist traffic. The study area is shown in Figure 1-1

A substantial portion of the developed area in Hood County is in unincorporated areas that do not have sewerage collection systems and centralized sewage treatment facilities. There are more than 40 rural water suppliers in Hood County, in addition to the Cities of Granbury and Lipan. There are eight permitted wastewater treatment plants in the county, and the population served by the existing permitted facilities is estimated to be less than 50 percent of the current county population. Development in areas without collection and treatment systems relies on individual on-site septic tanks and absorption fields.

There are an estimated 9,000 septic tanks located around Lake Granbury. Information provided by the sponsors of this study indicate that the soils in which septic tanks are installed around Lake Granbury are generally not well-suited for septic tanks and absorption fields, and that almost all such on-site systems around the lake include absorption fields that do not provide capacity that would comply with current criteria.

(This page is intentionally left blank.)

Fig 1-1
Foldout

1.3 Scope

Major scope items included in the study are:

1. Develop population and wastewater flow projections for the study area;
2. Inventory and evaluate existing wastewater facilities in the study area;
3. Identify collection system alternatives to provide a regional system to serve the study area;
4. Identify wastewater treatment alternatives to serve the study area;
5. Identify organizational structures appropriate for administration, management, and operation of a regional system;
6. Develop estimated capital and annual costs associated with implementation of a regional sewerage system;
7. Develop an implementation schedule for a regional system;
8. Develop recommendations for plan to be implemented; and
9. Prepare and present a summary report on the study.

Section 2

Population and Wastewater Flow Projections

2.1 Planning Basis

The regional sewer master plan for Hood County is being developed in a context of even broader regional and state water planning, also being funded by the TWDB. In 1997, the 75th Texas Legislature enacted Senate Bill 1 (SB1), which called for the development of regional-oriented plans to address the water needs of the State for the next 50 years. Hood County was included in the middle Brazos region termed “Brazos Area G.” This legislation also called for a framework of using consistent planning data and forecasts across the regions and state, to be initially provided by the TWDB and amended by the Board if better information could be provided by the regional planning groups. These forecasts were initially provided for local coordination and comment by the Board in 1995 as part of its State Water Plan efforts, and again provided for local comment more recently in 1999 by the SB1 regional planning group. This approved planning data for Brazos Area G projects population and water demands at 10-year intervals for the period 2000 to 2050 at the regional, county, city, rural utility, and county remainder (rural non-utility) levels. In particular, these population forecasts will be useful for projecting wastewater flows in this regional sewer study. For purposes of this particular infrastructure planning, a 20-year planning period is more appropriate and will be used.

2.2 Population Forecasts

Figure 2-1 and Table 2-1 lists the SB1-adopted population forecasts for Hood County, towns of Granbury and Tolar, various rural utilities, and the remainder of the county living in areas not yet served by organized water utilities. As indicated, Hood County population in the SB1 forecasts is expected to increase from its current level of about 42,000 to over 78,000 persons by the year 2030, an increase of 88 percent over the 30-year period, or a 2.15 percent compound annual rate of growth. The projected county growth in the SB1 forecasts is consistent with the annual historical trends of the last 20 years.

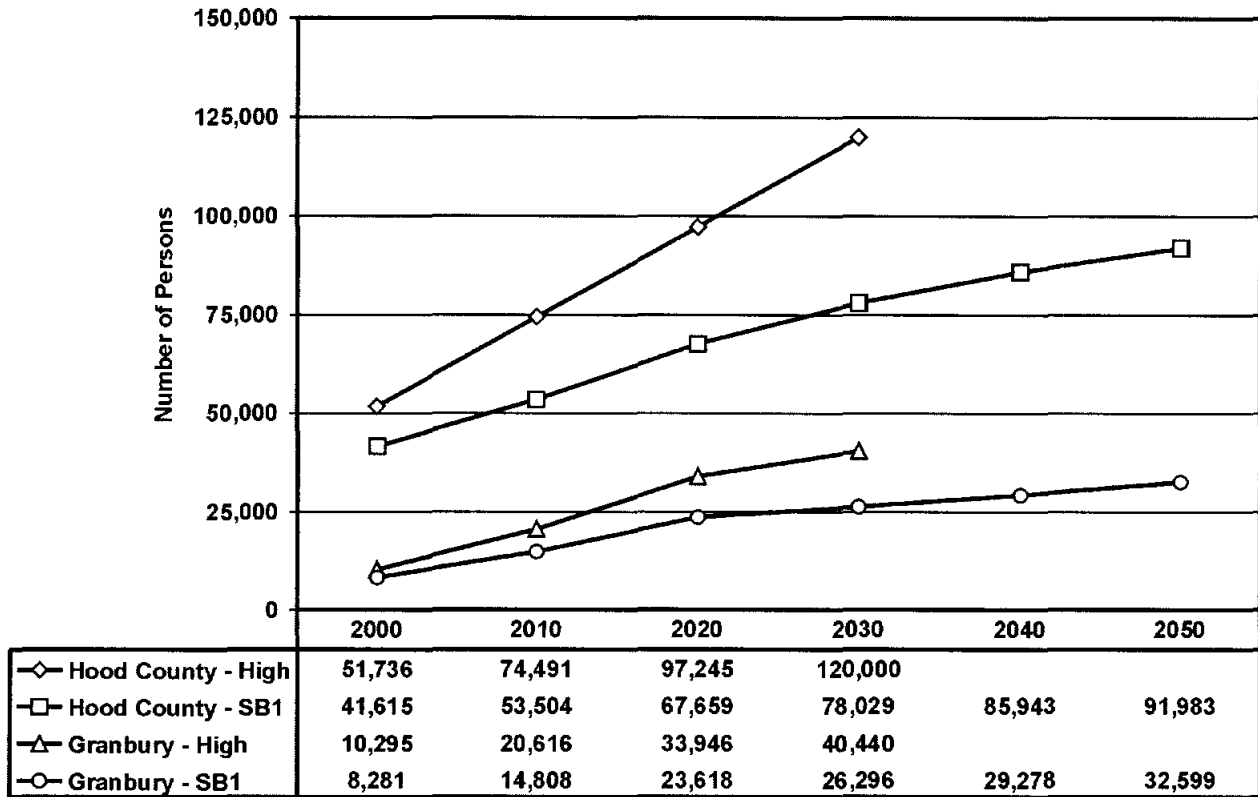

Figure 2-1. Projected Population

Table 2-1.
Hood County Population Based on SB1 Forecasts

Item	Historical Calculated from TWDB Data				Projected					
	1985	1990	1995	1996	2000	2010	2020	2030	2040	2050
Cities/Towns										
City Of Granbury	5,038	4,045	4,854	5,195	8,281	14,808	23,618	26,296	29,278	32,599
City Of Tolar					532	515	489	464	458	458
Rural Water Utilities										
Cresson Water Works	115	115	115	122	129	141	149	153	155	156
Oak Trail Shores Subdivision	2,260	2,213	2,349	2,506	2,607	2,768	2,869	2,921	2,948	2,961
Acton MUD	6,198	8,423	10,108	10,960	12,577	15,482	17,548	18,685	19,282	19,588
Acton Water Co. – Royal Oaks				175	182	193	200	204	206	207
Arrowhead Shores	744	856	974	1,000	1,061	1,160	1,225	1,258	1,275	1,284
Blue Water Shores	170	261	470	522	611	774	893	960	995	1,013
Boynton Water Supply		131	120	131	139	151	160	164	166	168
Brazos River Acres				282	288	296	302	304	306	306
Canyon Creek Addition	183	746	718	564	598	654	691	710	719	724

Table 2-1 (continued)

Item	Historical Calculated from TWDB Data				Projected					
	1985	1990	1995	1996	2000	2010	2020	2030	2040	2050
Comanche Cove	305	381	436	728	820	980	1,091	1,151	1,183	1,199
Comanche Harbor Ports O Call	966	1,054	1,125	1,159	1,230	1,345	1,420	1,458	1,478	1,488
Comanche Peak North				206	210	217	221	223	224	224
Country Meadows Subdivision				175	178	184	187	189	190	190
CPN Water Works	131	125	157	183	214	271	313	336	348	354
Eastwood Village				350	357	368	374	378	379	380
Highland Lakes	73	14	11	11	11	11	11	11	10	10
Hood County Water Co.	1,743	2,088	2,401	2,490	2,748	3,190	3,489	3,649	3,732	3,774
Laguna Tres Estates	305	399	438	441	468	512	540	555	563	566
Laguna Vista Subdivision		151	269	300	338	404	450	474	487	494
Lipan Water Works	352	373	414	518	565	644	697	725	740	747
Long Creek Water Co.	128	141	188	196	216	251	274	287	293	297
Mesa Grande WSC	245	266	292	284	302	330	349	358	363	365
Montego Bay Estates				269	274	283	288	290	292	292
Mooreland Water Co.	245	256	253	253	258	266	271	273	275	275
North Fork Creek No II				300	306	316	321	324	326	326
Rain Water Supply Corp.	63	81	86	89	94	103	109	112	113	114
Resort Water	245	287	274	287	311	350	376	390	397	401
Ridge Utilities		146	166	304	370	497	594	650	680	695
Rock Harbor Estates	222	248	287	256	271	297	313	322	326	328
Rolling Hills Water Service	253	240	256	261	275	297	311	319	322	324
Sandy Beach Subdivision				347	354	365	372	375	377	377
Scenic View Estates	99	26	110	110	119	134	144	149	152	153
Shady Grove Subdivision				193	197	203	207	209	210	210
Shores Utility Corporation	177	168	168	168	172	177	180	182	183	183
Sky Harbour WSC	540	522	632	647	766	988	1,152	1,245	1,294	1,319
Thorp Springs Water		37	26	26	26	26	26	26	26	26
Western Hills Harbor	835	877	958	987	1,060	1,180	1,258	1,300	1,321	1,332
Whipporwill Bay Subdivision				527	538	554	564	569	572	573
County Remainder (No Current Utility)										
Along NW Loop near Granbury	1,385	1,508	1,020	783	547	636	1,265	3,284	4,655	5,425
South of Hwy 377 at S. End of Loop	594	646	437	336	234	273	542	1,407	1,995	2,325
Infill between Granbury and Acton	1,187	1,293	874	671	469	545	1,084	2,815	3,990	4,650
Y Between Hwy 4 and Hwy 2580	237	259	175	134	94	109	217	563	798	930

Table 2-1 (continued)

Item	Historical Calculated from TWDB Data				Projected					
	1985	1990	1995	1996	2000	2010	2020	2030	2040	2050
Development East of Lake	237	259	175	134	94	109	217	563	798	930
Far NW	79	86	58	45	31	36	72	188	266	310
Far SW	79	86	58	45	31	36	72	188	266	310
Far NE	79	86	58	45	31	36	72	188	266	310
Far SE	79	86	58	45	31	36	72	188	266	310
Hood County Total	25,594	28,981	31,569	33,113	41,615	53,504	67,659	78,029	85,943	91,983

Some in Hood County have expressed concern that the SB1 forecasts are too low and that the current population already exceeds the SB1 year 2000 forecast. To address these concerns, a high case forecast was coordinated with the regional plan advisory committee that produces a county population of 120,000 by the year 2030. This forecast is also shown in Table 2-2 and Figure 2-1 and is used as the basis for some of the oversizing design. However, any request for state-funding assistance will be based on approved Board forecasts at that time.

Table 2-2.
Hood County Population Based on High Growth Forecasts

Item	Historical Calculated from TWDB Data				Projected			
	1985	1990	1995	1996	2000	2010	2020	2030
Cities/Towns								
City Of Granbury	5,038	4,045	8,031	8,484	10,295	20,616	33,946	40,440
City Of Tolar			516	545	661	717	703	714
Rural Water Utilities								
Cresson Water Works	115	115	125	132	61	197	214	235
Oak Trail Shores Subdivision	2,260	2,213	2,529	2,671	3,241	3,854	4,124	4,492
Acton MUD	6,198	8,423	12,197	12,885	15,636	21,555	25,221	28,735
Acton Water Co. – Royal Oaks			176	186	226	269	288	314
Arrowhead Shores	744	856	1,029	1,087	1,319	1,616	1,760	1,935
Blue Water Shores	170	261	592	626	759	1,078	1,284	1,476
Boynton Water Supply		131	134	142	172	211	230	252
Brazos River Acres			279	295	357	413	434	468
Canyon Creek Addition	183	746	580	613	744	911	993	1,092
Comanche Cove	305	381	795	840	1,019	1,364	1,568	1,770
Comanche Harbor Ports O Call	966	1,054	1,193	1,260	1,529	1,873	2,040	2,242
Comanche Peak North			204	215	262	302	317	343

The City of Granbury is projected to reach a population of about 26,000 people by the year 2030 in the SB1 forecasts and, alternately, to reach of population of about 40,000 persons by 2020 in the high case forecasts.

Figure 2-2 illustrates the SB1 county forecast subdivided into city (Granbury and Tolar) and what the TWDB terms “county other.” Currently, the large majority of the county population (about 80 percent) lives outside of Granbury and Tolar, but this is expected to change over time. These two larger communities are expected to increase from about 8,800 people currently (21 percent of the county population) to about 33,000 persons in 2050 (or 36 percent of the county). The “county other” population is also expected to grow significantly, adding over 26,000 new residents over the next 50 years.

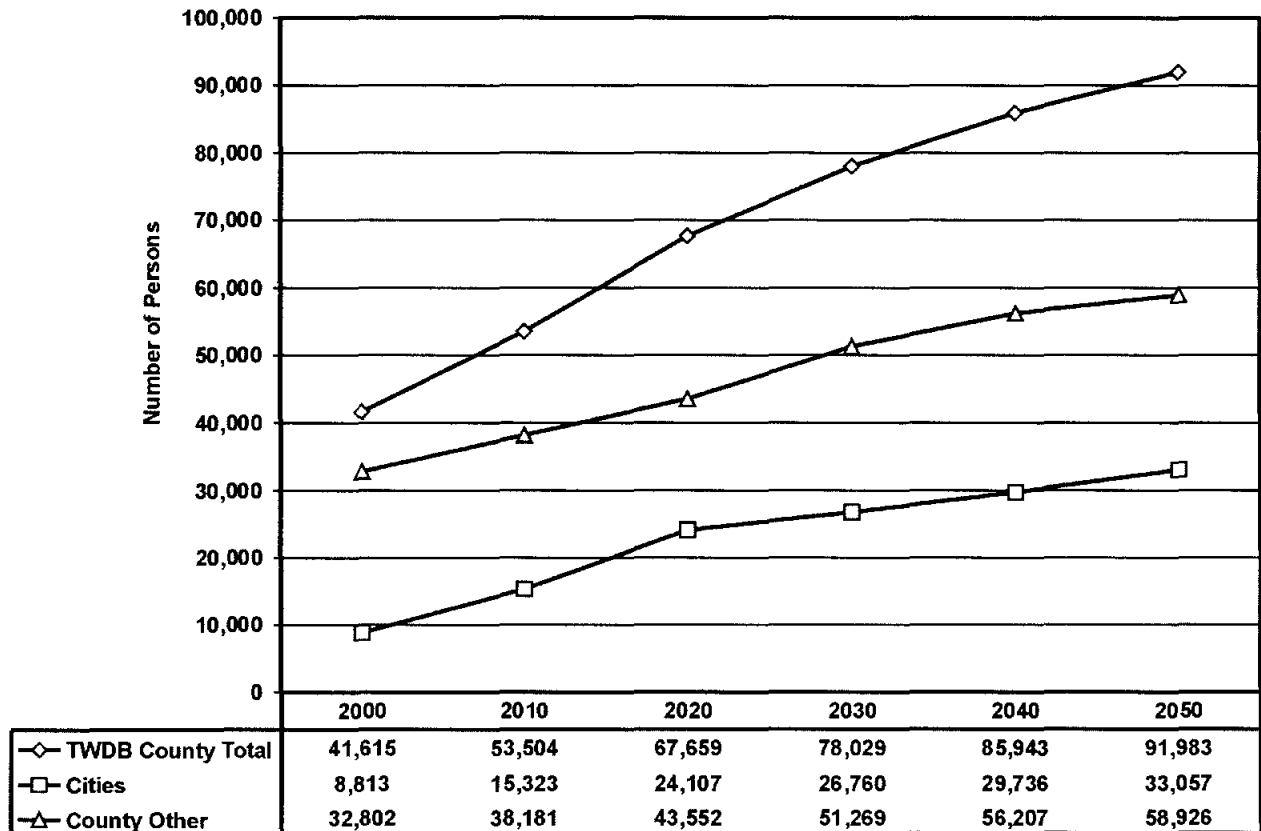

Figure 2-2. Projected Hood County Urban and Rural Population (SB1 Forecast)

Figure 2-3 subdivides the “county other” forecast into those living in areas served by rural utilities and a “county remainder” population in areas not yet served. Population in existing rural utilities is expected grow by about 12,100 persons over 50 years or to 39 percent of the county. At the same time, the “county remainder” population, outside of currently organized water and wastewater utilities, is expected to grow by about 13,900 persons, or 900 percent. It is very probable that existing utilities will expand or new utilities will organize over time to serve some of this projected rural population.

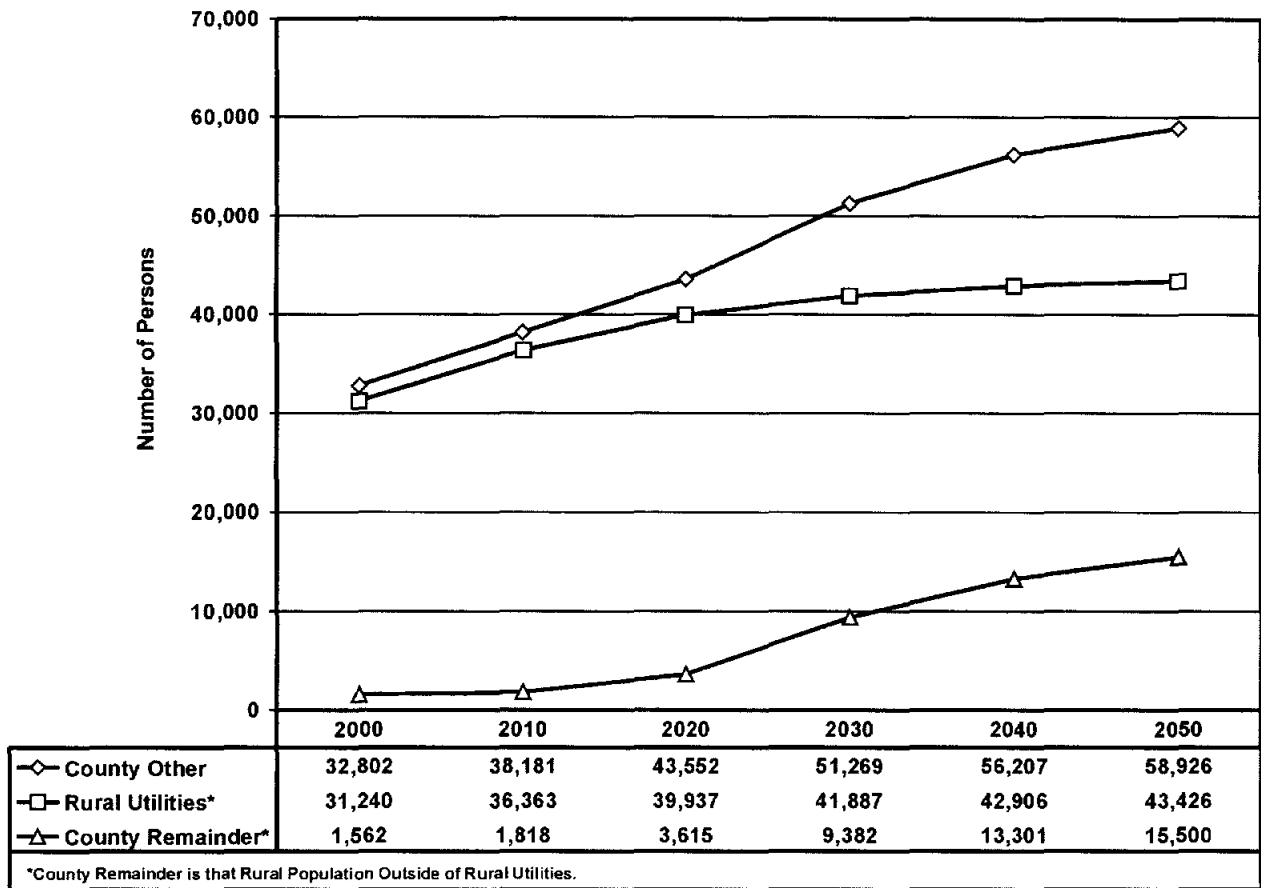

Figure 2-3. Projected Hood County “County Other” Population (SB1 Forecast)

As detailed at the bottom of Tables 2-1 and 2-2 and based on interviews with knowledgeable local officials, the “county remainder” population not currently served by utilities was further distributed into portions of the county or Granbury suburban area likely to experience this further growth.

2.3 Wastewater Flows

2.3.1 Existing Wastewater Flows

There are five existing wastewater utilities in the county, but only two with any substantial treatment flows—the City of Granbury and Acton MUD. Data was obtained from these two utilities to characterize the level of pattern of wastewater flows in these utilities as a basis for forecasting future wastewater service needs.

Trends in seasonal wastewater flows, peaking ratios, customer connections, and per capita (per person) wastewater flows for the City of Granbury Wastewater Treatment Plant (WWTP) are listed in Table 2-3 and graphed in Figure 2-4. As indicated, wastewater plant inflows are currently ranging at slightly below 1 million gallons per day (MGD) with occasional wet weather peak inflows in the 1.5 to 2.7 MGD range. Average per capita wastewater flows range from about 140 to 143 gallons per capita daily (gpcd), with peaks in the 160 to 180 gpcd range. Typically, average per capita wastewater flows tend to be lower than that experienced in the City of Granbury.

Wet weather peak infiltration and inflows to the plant are compounded with a higher “temporary” population in Granbury during autumn months, with children attending regional schools in the City. Further, Granbury serving as a commercial center for suburban and rural residents and a focus of tourism also acts to increase the average per capita wastewater flow experienced year-round by the City.

Trends in seasonal wastewater flows, peaking ratios, customer connections, and per capita wastewater flows for the two treatment plants of the Acton MUD are listed in Table 2-4 and graphed in Figures 2-5 and 2-6.

Table 2-3.
Granbury Daily Wastewater Inflow
(MGD)

<i>Month</i>	<i>Average</i>	<i>Maximum</i>	<i>Peak/Average</i>	<i>Connections</i>	<i>Average Flow per Person¹</i>
January 1996	0.620	0.668	1.1	1,901	130
February 1996	0.632	0.664	1.1	1,900	133
March 1996	0.670	0.910	1.4	1,908	140
April 1996	0.671	0.914	1.4	1,915	140
May 1996	0.679	0.813	1.2	1,924	141
June 1996	0.703	0.819	1.2	1,940	145
July 1996	0.687	0.819	1.2	1,659	166
August 1996	0.747	1.142	1.5	1,967	152
September 1996	0.734	0.908	1.2	1,972	149
October 1996	0.728	1.111	1.5	1,976	147
November 1996	0.745	1.002	1.3	1,980	151
December 1996	0.679	0.748	1.1	1,978	137
January 1997	0.690	0.908	1.3	1,978	140
February 1997	0.881	1.437	1.6	1,983	178
March 1997	0.777	1.324	1.7	1,986	156
April 1997	0.778	1.275	1.6	1,996	156
May 1997	0.826	1.467	1.8	2,002	165
June 1997	0.748	0.916	1.2	2,015	148
July 1997	0.708	0.822	1.2	2,031	139
August 1997	0.750	1.143	1.5	2,034	147
September 1997	0.726	0.807	1.1	2,055	141
October 1997	0.749	0.898	1.2	2,025	148
November 1997	0.704	0.807	1.1	2,037	138
December 1997	0.718	1.101	1.5	2,059	139
January 1998	0.701	0.831	1.2	2,030	138
February 1998	0.732	1.182	1.6	2,073	141
March 1998	0.822	1.461	1.8	2,033	162
April 1998	0.707	0.742	1.0	2,087	136
May 1998	0.697	0.873	1.3	2,089	133
June 1998	0.726	0.847	1.2	2,112	138
July 1998	0.818	1.126	1.4	2,133	153
August 1998	0.816	0.943	1.2	2,144	152
September 1998	0.744	0.940	1.3	2,173	137
October 1998	0.716	0.841	1.2	2,166	132
November 1998	0.725	1.970	2.7	2,152	135
December 1998	0.694	0.780	1.1	2,162	128
January 1999	0.696	0.804	1.2	2,169	128
February 1999	0.675	0.722	1.1	2,183	124
March 1999	0.689	0.828	1.2	2,215	124
April 1999	0.714	0.829	1.2	2,227	128
May 1999	0.742	0.840	1.1	2,242	132
June 1999	0.763	0.896	1.2	2,219	138
July 1999	0.800	0.917	1.1	2,237	143
August 1999	0.791	0.892	1.1	2,218	143

¹ Assumes 2.5 persons per connection.

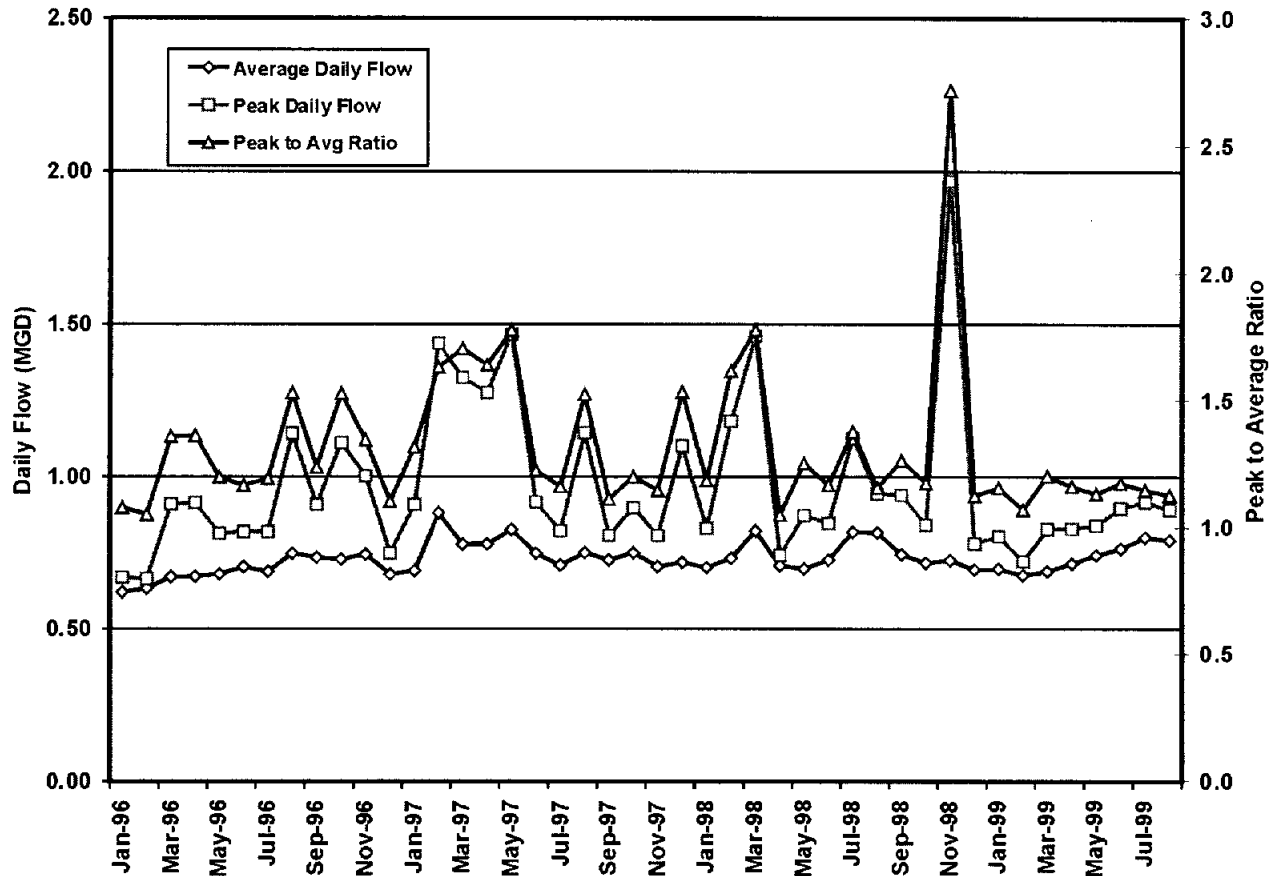

Figure 2-4. City of Granbury Wastewater Flows

As indicated in Figure 2-5, wastewater inflows to the DeCordova Bend WWTP, on the north side of Lake Granbury, are currently ranging at about 200,000 gallons per day (gpd) with occasional wet weather peak inflows in the 1.0 to 1.2 MGD range. The peak to average ratio typically ranges about 2.5, but has gone as high as 3.2 in recent years. Average per capita wastewater inflows range from about 80 to 93 gpcd with typical peaks in the 150 to 165 gpcd range, although there have been two extreme occurrences of inflow peaks of over 200 gpcd.

As indicated in Figure 2-6, wastewater inflows to the Pecan Plantation WWTP, on the south side of Lake Granbury, are currently ranging at about 155,000 gpd, with occasional wet weather peak inflows in the 0.5 to 0.7 MGD range. The peak to average ratio typically ranges about 2.5 to 3.0, but has gone as high as 3.7 in recent years. Average per capita wastewater flows range from about 78 to 81 gpcd, with peaks generally in the 120 to 130 gpcd range.

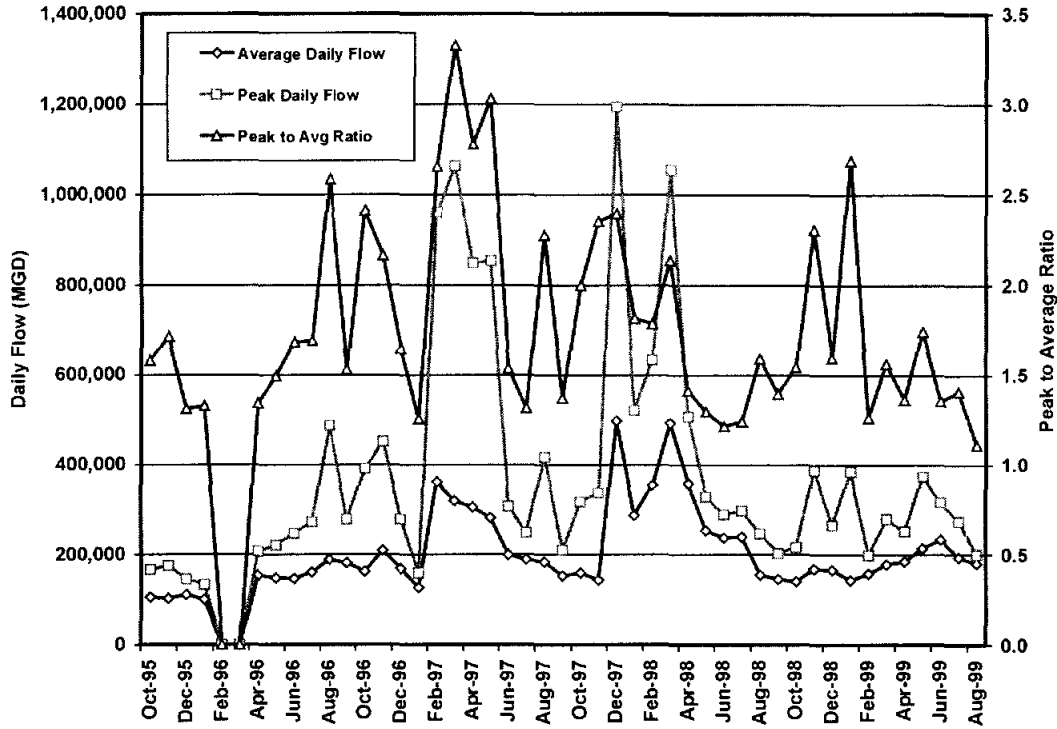

Figure 2-5. Acton MUD DeCordova Bend Wastewater Flows

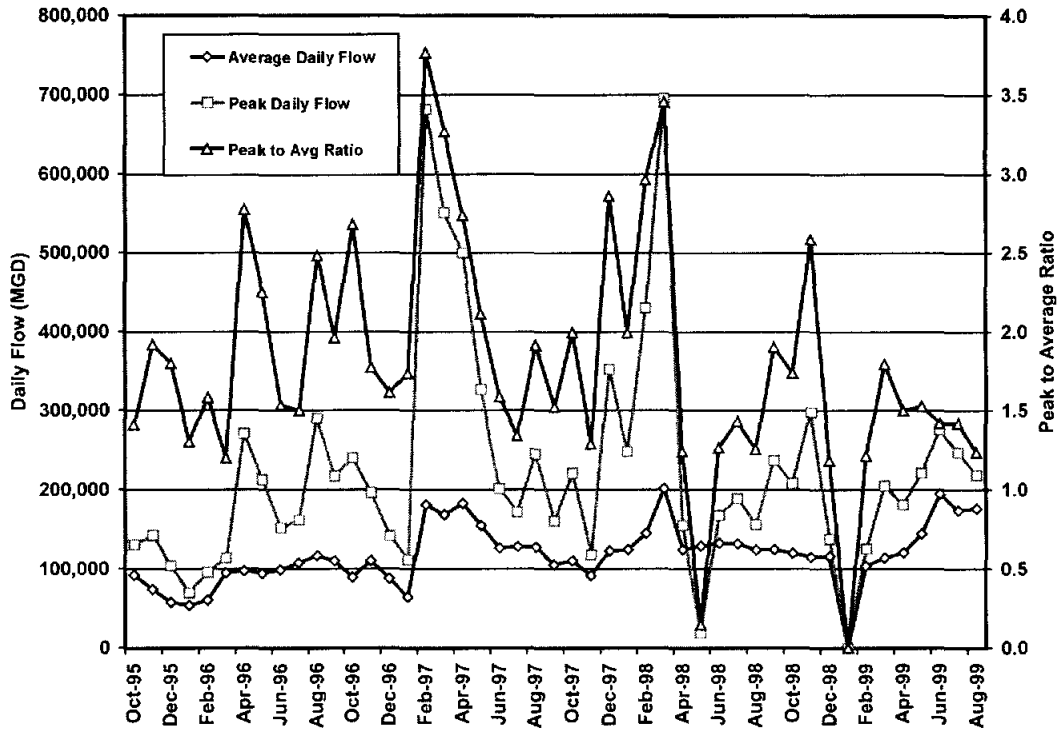

Figure 2-6. Acton MUD Pecan Plantation Wastewater Flows

Wet weather peak infiltration and inflows to the two Acton MUD plants are correlated with high rainfall event, but these two plants appear to have been more dramatically affected than did the nearby Granbury WWTP. The lack of significant commercial development and relatively older population residing in the District both act to reduce the average wastewater flow per capita below that of Granbury.

2.3.2 Projected Wastewater Flows

The typical methodology for projecting wastewater service demand is to apply a per capita wastewater flow factor to projected population.

Also, different concepts of wastewater flows are important in the planning and design of wastewater facilities, as described below:

Flow	Description and Comments
Average Annual Daily Flow	<ul style="list-style-type: none"> • Used as a basis of estimating other flows listed below. • Serves as a basis for estimating annual operation and maintenance costs for wastewater facilities.
Average Daily Flow During the Peak Month	<ul style="list-style-type: none"> • Used to determine the required TNRCC permitted monthly flow of wastewater treatment facilities. • One parameter used to establish the size of treatment unit components.
Peak Instantaneous Flow	<ul style="list-style-type: none"> • Used to determine the required capacity of all conveyance facilities (pipelines and lift stations). • One parameter used to establish the size of wastewater treatment units. • Along with the average daily flow during the peak month, the peak instantaneous flow is normally listed in the TNRCC permit (as the peak 2-hour flow).

Based on recent historical information, average annual daily, average daily during the peak month, and peak instantaneous flows for various portions of the Hood County study area were projected as indicated below.

Area	Basis of Flow
City of Granbury	<ul style="list-style-type: none"> • Average Annual Daily Flow – 140 gpcd based on historical data. • Average Daily Flow During the Peak Month – 1.25 times average annual daily flow, slightly higher than historical data. • Peak Instantaneous – 4 times average annual daily flow based on ratio considered appropriate based on consultant past experience.
Acton MUD	<ul style="list-style-type: none"> • Average Annual Daily Flow – 90 gpcd based on historical data. • Average Daily Flow During the Peak Month – 1.8 times average annual daily flow based on historical data. • Peak Instantaneous – 4 times average annual daily flow based on ratio considered appropriate based on consultant past experience.
Other Entities and Areas	<ul style="list-style-type: none"> • Average Annual Daily Flow – 100 gpcd based on TNRCC default value. • Average Daily Flow During the Peak Month – 1.3 times average annual daily flow based on consultant past experience. • Peak Instantaneous – 4 times average annual daily flow based on ratio considered appropriate based on consultant past experience.

These per capita service factors were applied to the population forecasts (shown in Tables 2-1 and 2-2) to produce the projected SB1 and high case wastewater service demands shown in Tables 2-5 to 2-10 and graphed in Figures 2-7 to 2-12. Figure 2-13 illustrates the location of the more significant average and peak daily wastewater service demands in the county.

Using the SB1 population forecasts, HDR estimates current Hood County *average annual daily* wastewater flows to total about 4.4 MGD, increasing to 5.8 MGD by 2010 and then to 8.7 MGD by the year 2030, an overall increase of 4.3 MGD or 98 percent over the 30-year period. Current Hood County *average daily flow during the peak month* wastewater flows, used in capacity requirements in wastewater permits, are estimated at about 5.5 MGD, increasing to 7.2 MGD by 2010 and then to 10.8 MGD by the year 2030, an overall increase of 5.3 MGD if the SB1 forecasts are used. Current Hood County *peak instantaneous* wastewater flows, used to determine the sewage conveyance capacity, are estimated at about 17.5 MGD, increasing to 23.2 MGD by 2010 and then to 34.7 MGD by the year 2030, an overall increase of 17.2 MGD under the SB1 population growth assumptions.

Using the high case population forecasts, HDR estimates current Hood County *average annual daily* wastewater flows to total about 5.4 MGD, increasing to 8.0 MGD by 2010 and then to 13.3 MGD by the year 2030, an overall increase of 6.8 MGD, or 103 percent over the 30-year period. Current Hood County *average daily flow during the peak month* wastewater flows, used in capacity requirements in wastewater permits, are estimated at about 6.7 MGD, increasing to 10.0 MGD by 2010 and then to 16.7 MGD by the year 2030, an overall increase of 8.9 MGD if the high case forecasts are used. Current Hood County *peak instantaneous* wastewater flows, used to determine sewage conveyance capacity, are estimated at about 21.7 MGD, increasing to 32.2 MGD by 2010 and then to 53.5 MGD by the year 2030, an overall increase of 28.6 MGD under the high case population growth assumptions.

Table 2-5.
Average Daily Wastewater Flows with SB1 Population*
(MGD)

Item	Projected					
	2000	2010	2020	2030	2040	2050
Cities/Towns						
City Of Granbury	1.159	2.073	3.307	3.681	4.099	4.564
City Of Tolar	0.053	0.052	0.049	0.046	0.046	0.046
Rural Water Utilities						
Cresson Water Works	0.013	0.014	0.015	0.015	0.016	0.016
Oak Trail Shores Subdivision	0.261	0.277	0.287	0.292	0.295	0.296
Acton MUD	1.132	1.393	1.579	1.682	1.735	1.763
Acton Water Co. – Royal Oaks	0.018	0.019	0.020	0.020	0.021	0.021
Arrowhead Shores	0.106	0.116	0.122	0.126	0.128	0.128
Blue Water Shores	0.061	0.077	0.089	0.096	0.100	0.101
Boynton Water Supply	0.014	0.015	0.016	0.016	0.017	0.017
Brazos River Acres	0.029	0.030	0.030	0.030	0.031	0.031
Canyon Creek Addition	0.060	0.065	0.069	0.071	0.072	0.072
Comanche Cove	0.082	0.098	0.109	0.115	0.118	0.120
Comanche Harbor Ports O Call	0.123	0.135	0.142	0.146	0.148	0.149
Comanche Peak North	0.021	0.022	0.022	0.022	0.022	0.022
Country Meadows Subdivision	0.018	0.018	0.019	0.019	0.019	0.019
CPN Water Works	0.021	0.027	0.031	0.034	0.035	0.035
Eastwood Village	0.036	0.037	0.037	0.038	0.038	0.038
Highland Lakes	0.001	0.001	0.001	0.001	0.001	0.001
Hood County Water Co.	0.275	0.319	0.349	0.365	0.373	0.377
Laguna Tres Estates	0.047	0.051	0.054	0.056	0.056	0.057
Laguna Vista Subdivision	0.034	0.040	0.045	0.047	0.049	0.049
Lipan Water Works	0.057	0.064	0.070	0.073	0.074	0.075
Long Creek Water Co.	0.022	0.025	0.027	0.029	0.029	0.30
Mesa Grande WSC	0.030	0.033	0.035	0.036	0.036	0.037
Montego Bay Estates	0.027	0.028	0.029	0.029	0.029	0.029
Mooreland Water Co.	0.026	0.027	0.027	0.027	0.028	0.028
North Fork Creek No II	0.031	0.032	0.032	0.032	0.033	0.033
Rain Water Supply Corp.	0.009	0.010	0.011	0.011	0.011	0.011
Resort Water	0.031	0.035	0.038	0.039	0.040	0.040
Ridge Utilities	0.037	0.050	0.059	0.065	0.068	0.070
Rock Harbor Estates	0.027	0.030	0.031	0.032	0.033	0.033
Rolling Hills Water Service	0.027	0.030	0.031	0.032	0.032	0.032
Sandy Beach Subdivision	0.035	0.036	0.037	0.038	0.038	0.038

Table 2-5 (continued)

Item	Projected					
	2000	2010	2020	2030	2040	2050
Scenic View Estates	0.012	0.013	0.014	0.015	0.015	0.015
Shady Grove Subdivision	0.020	0.020	0.021	0.021	0.021	0.021
Shores Utility Corporation	0.017	0.018	0.018	0.018	0.018	0.018
Sky Harbour WSC	0.077	0.099	0.115	0.124	0.129	0.132
Thorp Springs Water	0.003	0.003	0.003	0.003	0.003	0.003
Western Hills Harbor	0.106	0.118	0.126	0.130	0.132	0.133
Whipporwill Bay Subdivision	0.054	0.055	0.056	0.057	0.057	0.057
County Remainder (No Current Utility)						
Along NW Loop near Granbury	0.055	0.064	0.127	0.328	0.466	0.543
South of Hwy 377 at S. End of Loop	0.023	0.027	0.054	0.141	0.200	0.233
Infill between Granbury and Acton	0.047	0.055	0.108	0.281	0.399	0.465
Y Between Hwy 4 and Hwy 2580	0.009	0.011	0.022	0.056	0.80	0.093
Development East of Lake	0.009	0.011	0.022	0.056	0.080	0.093
Far NW	0.003	0.004	0.007	0.019	0.027	0.031
Far SW	0.003	0.004	0.007	0.019	0.027	0.031
Far NE	0.003	0.004	0.007	0.019	0.027	0.031
Far SE	0.003	0.004	0.007	0.019	0.027	0.031
Hood County Total	4.367	5.788	7.535	8.668	9.573	10.306

*Includes infiltration and inflows allowable.

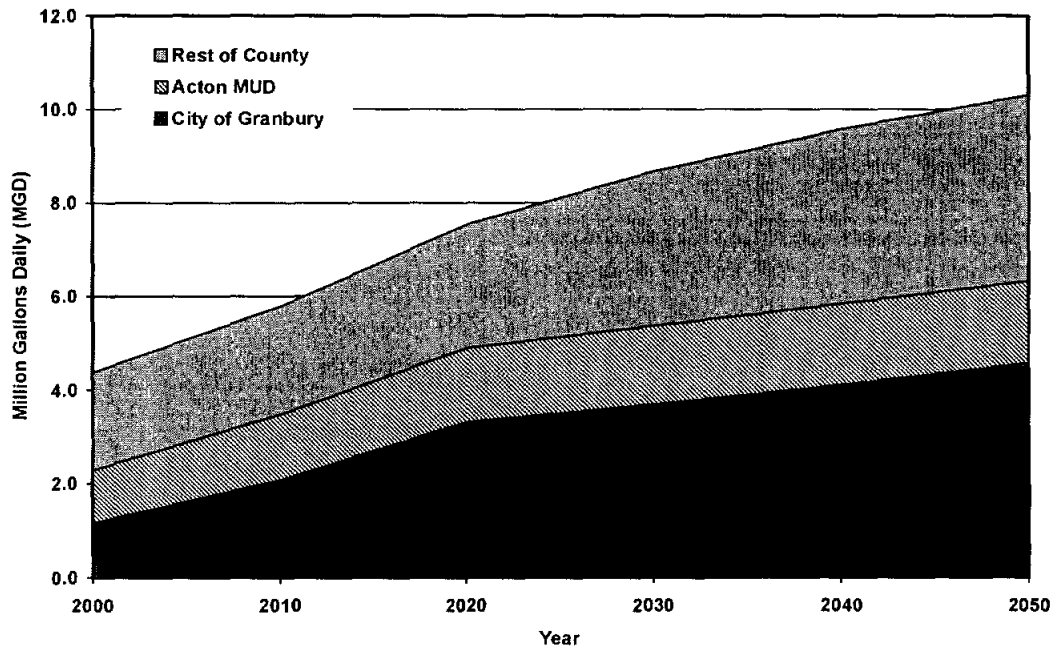

Figure 2-7. Average Annual Daily Wastewater Flows Hood County SB1 Population

Table 2-6.
Average Daily Wastewater Flows with High Case Population*
(MGD)

Item	Projected			
	2000	2010	2020	2030
Cities/Towns				
City Of Granbury	1.441	2.886	4.752	5.662
City Of Tolar	0.066	0.072	0.070	0.071
Rural Water Utilities				
Cresson Water Works	0.016	0.020	0.021	0.024
Oak Trail Shores Subdivision	0.324	0.385	0.412	0.449
Acton MUD	1.407	1.940	2.270	2.586
Acton Water Co. – Royal Oaks	0.023	0.027	0.029	0.031
Arrowhead Shores	0.132	0.162	0.176	0.193
Blue Water Shores	0.076	0.108	0.128	0.148
Boynton Water Supply	0.017	0.021	0.023	0.025
Brazos River Acres	0.036	0.041	0.043	0.047
Canyon Creek Addition	0.074	0.091	0.099	0.109
Comanche Cove	0.102	0.136	0.157	0.177
Comanche Harbor Ports O Call	0.153	0.187	0.204	0.224
Comanche Peak North	0.026	0.030	0.032	0.034
Country Meadows Subdivision	0.022	0.026	0.027	0.029
CPN Water Works	0.027	0.038	0.045	0.052
Eastwood Village	0.044	0.051	0.054	0.058
Highland Lakes	0.001	0.002	0.002	0.002
Hood County Water Co.	0.342	0.444	0.501	0.561
Laguna Tres Estates	0.058	0.071	0.078	0.085
Laguna Vista Subdivision	0.042	0.056	0.065	0.073
Lipan Water Works	0.070	0.090	0.100	0.111
Long Creek Water Co.	0.027	0.035	0.039	0.044
Mesa Grande WSC	0.038	0.046	0.050	0.055
Montego Bay Estates	0.034	0.039	0.041	0.045
Mooreland Water Co.	0.032	0.037	0.039	0.042
North Fork Creek No II	0.038	0.044	0.046	0.050
Rain Water Supply Corp.	0.012	0.014	0.016	0.017
Resort Water	0.039	0.049	0.054	0.060
Ridge Utilities	0.046	0.069	0.085	0.100
Rock Harbor Estates	0.034	0.041	0.045	0.050
Rolling Hills Water Service	0.034	0.041	0.045	0.049
Sandy Beach Subdivision	0.044	0.051	0.053	0.058
Scenic View Estates	0.015	0.019	0.021	0.023
Shady Grove Subdivision	0.024	0.028	0.030	0.032
Shores Utility Corporation	0.021	0.025	0.026	0.028
Sky Harbour WSC	0.095	0.138	0.166	0.191
Thorp Springs Water	0.003	0.004	0.004	0.004
Western Hills Harbor	0.132	0.164	0.181	0.200
Whipporwill Bay Subdivision	0.067	0.077	0.081	0.088

Table 2-6 (continued)

Item	Projected			
	2000	2010	2020	2030
County Remainder (No Current Utility)				
Along NW Loop near Granbury	0.068	0.089	0.182	0.505
South of Hwy 377 at S. End of Loop	0.029	0.038	0.078	0.216
Infill between Granbury and Acton	0.058	0.076	0.156	0.433
Y Between Hwy 4 and Hwy 2580	0.012	0.015	0.031	0.087
Development East of Lake	0.012	0.015	0.031	0.087
Far NW	0.004	0.005	0.010	0.029
Far SW	0.004	0.005	0.010	0.029
Far NE	0.004	0.005	0.010	0.029
Far SE	0.004	0.005	0.010	0.029
Hood County Total	5.429	8.058	10.830	13.330

*Includes infiltration and inflows allowable.

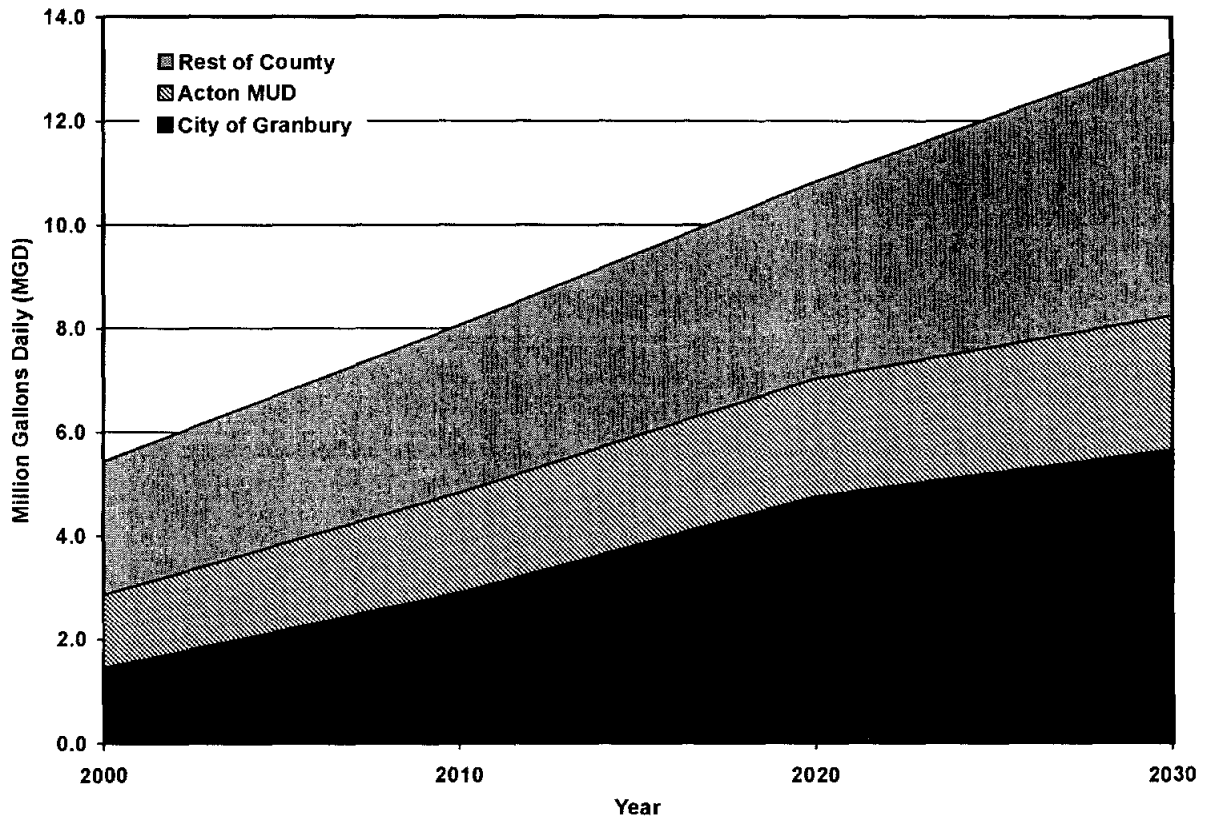

Figure 2-8. Average Annual Daily Wastewater Flows Hood County High Case Population

**Table 2-7.
Peak Daily Wastewater Flow with SB1 Population*
(MGD)**

Item	Projected					
	2000	2010	2020	2030	2040	2050
Cities/Towns						
City Of Granbury	1.449	2.591	4.133	4.602	5.124	5.705
City Of Tolar	0.067	0.064	0.061	0.058	0.057	0.057
Rural Water Utilities						
Cresson Water Works	0.016	0.018	0.019	0.019	0.019	0.020
Oak Trail Shores Subdivision	0.326	0.346	0.359	0.365	0.369	0.370
Acton MUD	1.415	1.742	1.974	2.102	2.169	2.204
Acton Water Co. – Royal Oaks	0.023	0.024	0.025	0.026	0.026	0.026
Arrowhead Shores	0.133	0.145	0.153	0.157	0.159	0.161
Blue Water Shores	0.076	0.097	0.112	0.120	0.124	0.127
Boynton Water Supply	0.017	0.019	0.020	0.021	0.021	0.021
Brazos River Acres	0.036	0.037	0.038	0.038	0.038	0.038
Canyon Creek Addition	0.075	0.082	0.086	0.089	0.090	0.091
Comanche Cove	0.102	0.122	0.136	0.144	0.148	0.150
Comanche Harbor Ports O Call	0.154	0.168	0.177	0.182	0.185	0.186
Comanche Peak North	0.026	0.027	0.028	0.028	0.028	0.028
Country Meadows Subdivision	0.022	0.023	0.023	0.024	0.024	0.024
CPN Water Works	0.027	0.034	0.039	0.042	0.044	0.044
Eastwood Village	0.045	0.046	0.047	0.047	0.047	0.048
Highland Lakes	0.001	0.001	0.001	0.001	0.001	0.001
Hood County Water Co.	0.344	0.399	0.436	0.456	0.467	0.472
Laguna Tres Estates	0.059	0.064	0.068	0.069	0.070	0.071
Laguna Vista Subdivision	0.042	0.050	0.056	0.059	0.061	0.062
Lipan Water Works	0.071	0.081	0.087	0.091	0.093	0.093
Long Creek Water Co.	0.027	0.031	0.034	0.036	0.037	0.037
Mesa Grande WSC	0.038	0.041	0.044	0.045	0.045	0.046
Montego Bay Estates	0.034	0.035	0.036	0.036	0.037	0.037
Mooreland Water Co.	0.032	0.033	0.034	0.034	0.034	0.034
North Fork Creek No II	0.038	0.039	0.040	0.041	0.041	0.041
Rain Water Supply Corp.	0.012	0.013	0.014	0.014	0.014	0.014
Resort Water	0.039	0.044	0.047	0.049	0.050	0.050
Ridge Utilities	0.046	0.062	0.074	0.081	0.085	0.087
Rock Harbor Estates	0.034	0.037	0.039	0.040	0.041	0.041
Rolling Hills Water Service	0.034	0.037	0.039	0.040	0.040	0.041
Sandy Beach Subdivision	0.044	0.046	0.046	0.047	0.047	0.047
Scenic View Estates	0.015	0.017	0.018	0.019	0.019	0.019
Shady Grove Subdivision	0.025	0.025	0.026	0.026	0.026	0.026
Shores Utility Corporation	0.021	0.022	0.023	0.023	0.023	0.023
Sky Harbour WSC	0.096	0.124	0.144	0.156	0.162	0.165
Thorp Springs Water	0.003	0.003	0.003	0.003	0.003	0.003

Table 2-7 (continued)

Item	Projected					
	2000	2010	2020	2030	2040	2050
Western Hills Harbor	0.132	0.147	0.157	0.163	0.165	0.167
Whipporwill Bay Subdivision	0.067	0.069	0.071	0.071	0.072	0.072
County Remainder (No Current Utility)						
Along NW Loop near Granbury	0.068	0.080	0.158	0.410	0.582	0.678
South of Hwy 377 at S. End of Loop	0.029	0.034	0.068	0.176	0.249	0.291
Infill between Granbury and Acton	0.059	0.068	0.136	0.352	0.499	0.581
Y Between Hwy 4 and Hwy 2580	0.012	0.014	0.027	0.070	0.100	0.116
Development East of Lake	0.012	0.014	0.027	0.070	0.100	0.116
Far NW	0.004	0.005	0.009	0.023	0.033	0.039
Far SW	0.004	0.005	0.009	0.023	0.033	0.039
Far NE	0.004	0.005	0.009	0.023	0.033	0.039
Far SE	0.004	0.005	0.009	0.023	0.033	0.039
Hood County Total	5.459	7.235	9.419	10.835	11.966	12.883

*Includes infiltration and inflows allowable.

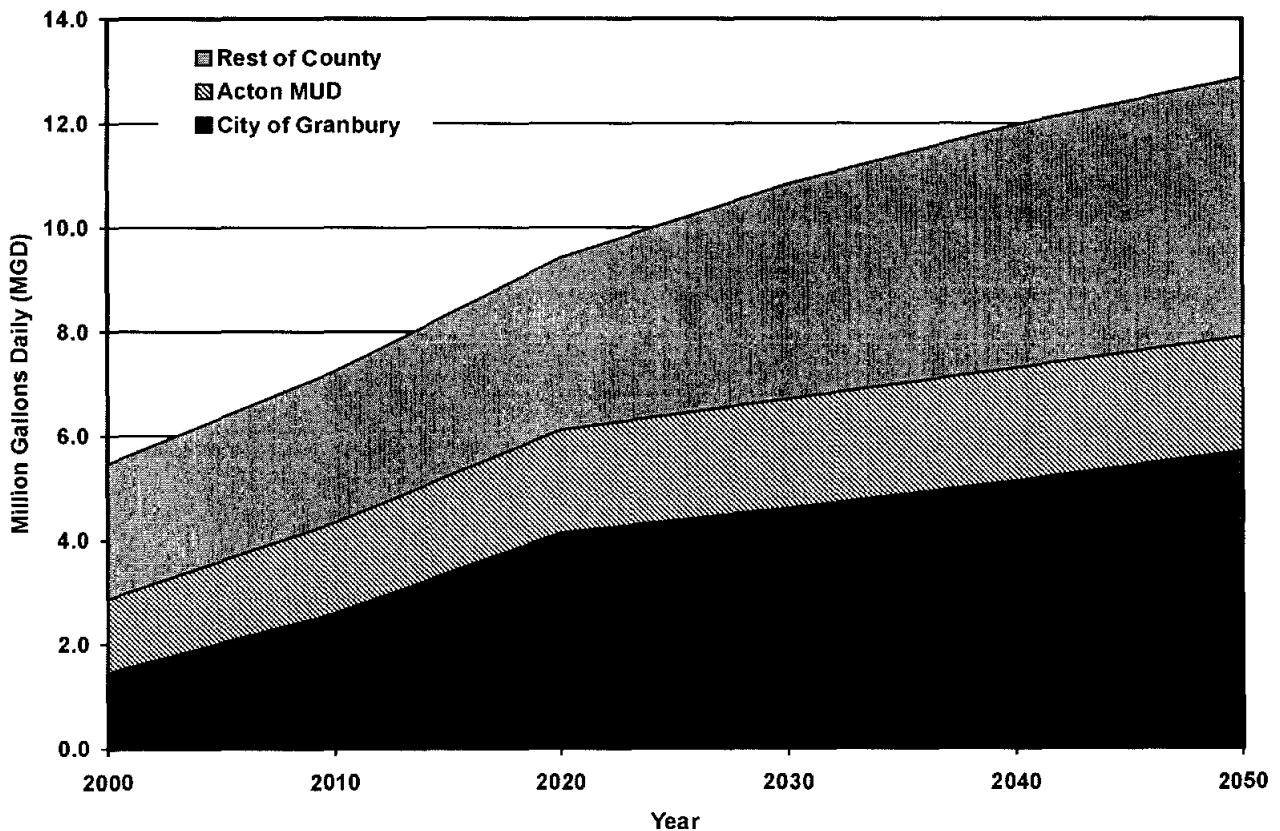

Figure 2-9. Average Daily Flow During the Peak Month Hood County SB1 Population

Table 2-8.
Average Daily Flow During the Peak Month with High Case Population*
(MGD)

Item	Projected			
	2000	2010	2020	2030
Cities/Towns				
City Of Granbury	1.802	3.608	5.941	7.077
City Of Tolar	0.083	0.090	0.088	0.089
Rural Water Utilities				
Cresson Water Works	0.020	0.025	0.027	0.029
Oak Trail Shores Subdivision	0.405	0.482	0.516	0.562
Acton MUD	1.759	2.425	2.837	3.233
Acton Water Co. – Royal Oaks	0.028	0.034	0.036	0.039
Arrowhead Shores	0.165	0.202	0.220	0.242
Blue Water Shores	0.095	0.135	0.160	0.185
Boynton Water Supply	0.022	0.026	0.029	0.032
Brazos River Acres	0.045	0.052	0.054	0.058
Canyon Creek Addition	0.093	0.114	0.124	0.136
Comanche Cove	0.127	0.170	0.196	0.221
Comanche Harbor Ports O Call	0.191	0.234	0.255	0.280
Comanche Peak North	0.033	0.038	0.040	0.043
Country Meadows Subdivision	0.028	0.032	0.034	0.036
CPN Water Works	0.033	0.047	0.056	0.065
Eastwood Village	0.055	0.064	0.067	0.073
Highland Lakes	0.002	0.002	0.002	0.002
Hood County Water Co.	0.427	0.555	0.627	0.701
Laguna Tres Estates	0.073	0.089	0.097	0.107
Laguna Vista Subdivision	0.052	0.070	0.081	0.091
Lipan Water Works	0.088	0.112	0.125	0.139
Long Creek Water Co.	0.034	0.044	0.049	0.055
Mesa Grande WSC	0.047	0.057	0.063	0.069
Montego Bay Estates	0.043	0.049	0.052	0.056
Mooreland Water Co.	0.040	0.046	0.049	0.052
North Fork Creek No II	0.048	0.055	0.058	0.062
Rain Water Supply Corp.	0.015	0.018	0.020	0.022
Resort Water	0.048	0.061	0.068	0.075
Ridge Utilities	0.057	0.087	0.107	0.125
Rock Harbor Estates	0.042	0.052	0.056	0.062
Rolling Hills Water Service	0.043	0.052	0.056	0.061
Sandy Beach Subdivision	0.055	0.064	0.067	0.072
Scenic View Estates	0.018	0.023	0.026	0.029
Shady Grove Subdivision	0.031	0.035	0.037	0.040
Shores Utility Corporation	0.027	0.031	0.032	0.035
Sky Harbour WSC	0.119	0.172	0.207	0.239
Thorp Springs Water	0.004	0.005	0.005	0.005
Western Hills Harbor	0.165	0.205	0.226	0.250
Whipponwill Bay Subdivision	0.084	0.096	0.101	0.109

Table 2-8 (continued)

Item	Projected			
	2000	2010	2020	2030
County Remainder (No Current Utility)				
Along NW Loop near Granbury	0.085	0.111	0.227	0.631
South of Hwy 377 at S. End of Loop	0.036	0.047	0.097	0.271
Infill between Granbury and Acton	0.073	0.095	0.195	0.541
Y Between Hwy 4 and Hwy 2580	0.015	0.019	0.039	0.108
Development East of Lake	0.015	0.019	0.039	0.108
Far NW	0.005	0.006	0.013	0.036
Far SW	0.005	0.006	0.013	0.036
Far NE	0.005	0.006	0.013	0.036
Far SE	0.005	0.006	0.013	0.036
Hood County Total	6.786	10,073	13,538	16,663
*Includes infiltration and inflows allowable.				

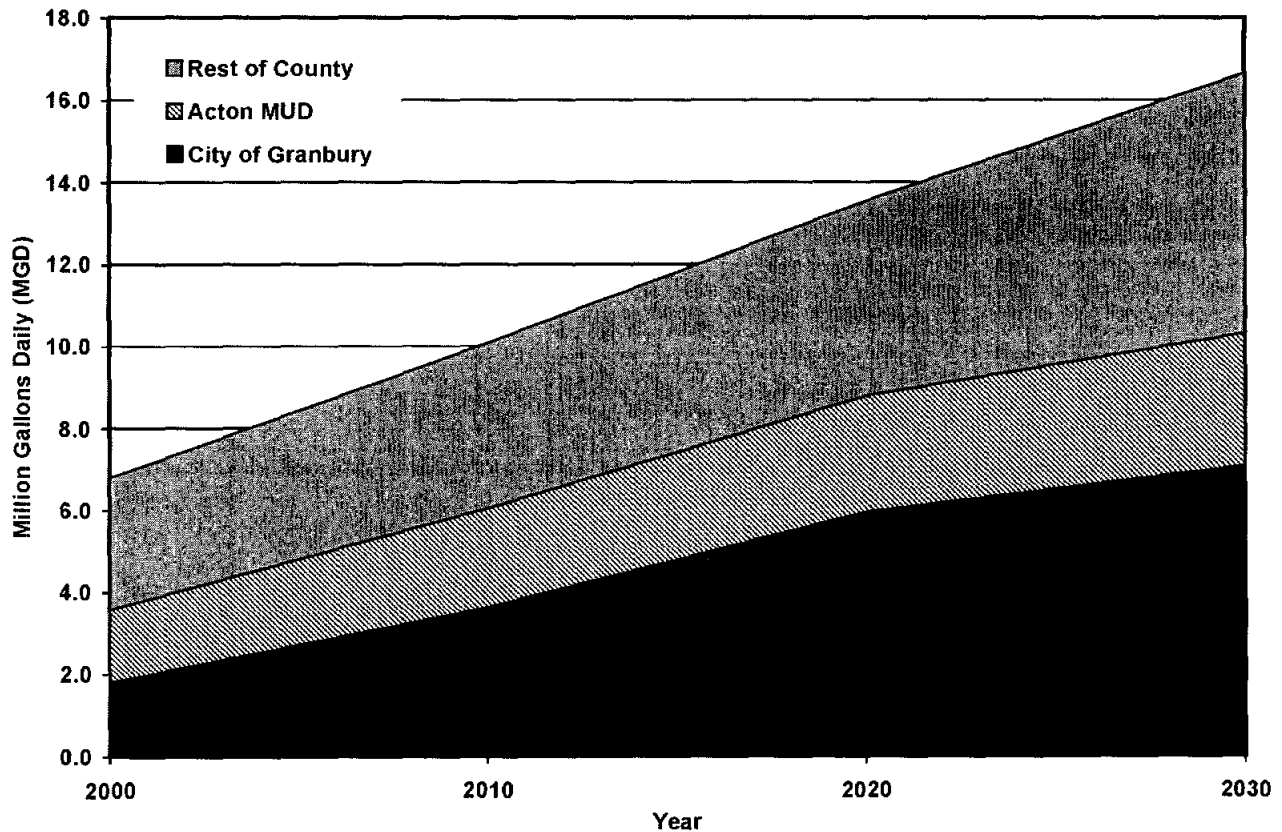

Figure 2-10. Average Daily Flow During the Peak Month Hood County High Case Population

Table 2-9.
Peak Instantaneous Wastewater Flows with SB1 Population*
(MGD)

Item	Projected					
	2000	2010	2020	2030	2040	2050
Cities/Towns						
City Of Granbury	4.637	8.292	13.226	14.726	16.396	18.255
City Of Tolar	0.213	0.206	0.196	0.186	0.183	0.183
Rural Water Utilities						
Cresson Water Works	0.052	0.057	0.060	0.061	0.062	0.062
Oak Trail Shores Subdivision	1.043	1.107	1.148	1.168	1.179	1.184
Acton MUD	4.528	5.574	6.317	6.727	6.942	7.052
Acton Water Co. – Royal Oaks	0.073	0.077	0.080	0.082	0.082	0.083
Arrowhead Shores	0.424	0.464	0.490	0.503	0.510	0.514
Blue Water Shores	0.244	0.310	0.357	0.384	0.398	0.405
Boynton Water Supply	0.055	0.061	0.064	0.066	0.066	0.067
Brazos River Acres	0.115	0.119	0.121	0.122	0.122	0.122
Canyon Creek Addition	0.239	0.262	0.276	0.284	0.288	0.290
Comanche Cove	0.328	0.392	0.436	0.460	0.473	0.480
Comanche Harbor Ports O Call	0.492	0.538	0.568	0.583	0.591	0.595
Comanche Peak North	0.084	0.087	0.088	0.089	0.090	0.090
Country Meadows Subdivision	0.071	0.074	0.075	0.076	0.076	0.076
CPN Water Works	0.085	0.108	0.125	0.134	0.139	0.142
Eastwood Village	0.143	0.147	0.150	0.151	0.152	0.152
Highland Lakes	0.004	0.004	0.004	0.004	0.004	0.004
Hood County Water Co.	1.099	1.276	1.395	1.460	1.493	1.510
Laguna Tres Estates	0.187	0.205	0.216	0.222	0.225	0.226
Laguna Vista Subdivision	0.135	0.162	0.180	0.190	0.195	0.198
Lipan Water Works	0.226	0.258	0.279	0.290	0.296	0.299
Long Creek Water Co.	0.086	0.100	0.110	0.115	0.117	0.119
Mesa Grande WSC	0.121	0.132	0.139	0.143	0.145	0.146
Montego Bay Estates	0.110	0.113	0.115	0.116	0.117	0.117
Mooreland Water Co.	0.103	0.106	0.108	0.109	0.110	0.110
North Fork Creek No II	0.122	0.126	0.128	0.130	0.130	0.131
Rain Water Supply Corp.	0.038	0.041	0.043	0.045	0.045	0.046
Resort Water	0.124	0.140	0.150	0.156	0.159	0.161
Ridge Utilities	0.148	0.199	0.238	0.260	0.272	0.278
Rock Harbor Estates	0.109	0.119	0.125	0.129	0.130	0.131
Rolling Hills Water Service	0.110	0.119	0.124	0.128	0.129	0.130
Sandy Beach Subdivision	0.142	0.146	0.149	0.150	0.151	0.151
Scenic View Estates	0.047	0.053	0.057	0.059	0.061	0.061
Shady Grove Subdivision	0.079	0.081	0.083	0.084	0.084	0.084
Shores Utility Corporation	0.069	0.071	0.072	0.073	0.073	0.073
Sky Harbour WSC	0.306	0.395	0.461	0.498	0.518	0.528
Thorp Springs Water	0.010	0.010	0.010	0.010	0.010	0.011

Table 2-9 (continued)

Item	Projected					
	2000	2010	2020	2030	2040	2050
Western Hills Harbor	0.424	0.472	0.503	0.520	0.528	0.533
Whipporwill Bay Subdivision	0.215	0.222	0.226	0.228	0.229	0.229
County Remainder (No Current Utility)						
Along NW Loop near Granbury	0.219	0.255	0.506	1.313	1.862	2.170
South of Hwy 377 at S. End of Loop	0.094	0.109	0.217	0.563	0.798	0.930
Infill between Granbury and Acton	0.187	0.218	0.434	1.126	1.596	1.860
Y Between Hwy 4 and Hwy 2580	0.037	0.044	0.087	0.225	0.319	0.372
Development East of Lake	0.037	0.044	0.087	0.225	0.319	0.372
Far NW	0.012	0.015	0.029	0.075	0.106	0.124
Far SW	0.012	0.015	0.029	0.075	0.106	0.124
Far NE	0.012	0.015	0.029	0.075	0.106	0.124
Far SE	0.012	0.015	0.029	0.075	0.106	0.124
Hood County Total	17.468	23.151	30.141	34.672	38.291	41.225

*Includes infiltration and inflows allowable.

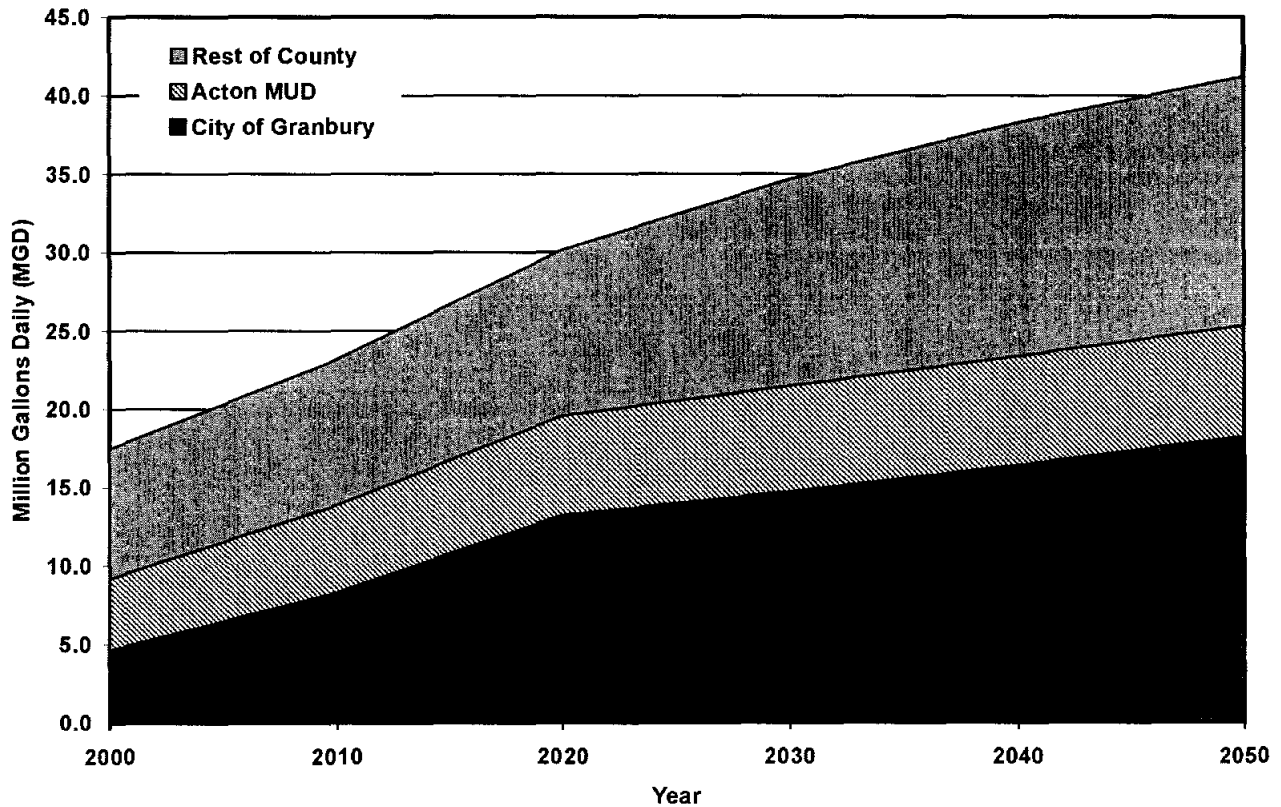

Figure 2-11. Peak Instantaneous Wastewater Flows Hood County SB1 Population

Table 2-10.
Peak Instantaneous Wastewater Flows with High Case Population*
(MGD)

Item	Projected			
	2000	2010	2020	2030
Cities/Towns				
City Of Granbury	5.765	11.545	19.010	22.647
City Of Tolar	0.265	0.287	0.281	0.285
Rural Water Utilities				
Cresson Water Works	0.064	0.079	0.086	0.094
Oak Trail Shores Subdivision	1.297	1.542	1.650	1.797
Acton MUD	5.629	7.760	9.079	10.345
Acton Water Co. – Royal Oaks	0.090	0.108	0.115	0.125
Arrowhead Shores	0.528	0.646	0.704	0.774
Blue Water Shores	0.304	0.431	0.513	0.591
Boynton Water Supply	0.069	0.084	0.092	0.101
Brazos River Acres	0.143	0.165	0.173	0.187
Canyon Creek Addition	0.298	0.364	0.397	0.437
Comanche Cove	0.408	0.546	0.627	0.708
Comanche Harbor Ports O Call	0.612	0.749	0.816	0.897
Comanche Peak North	0.105	0.121	0.127	0.137
Country Meadows Subdivision	0.089	0.102	0.108	0.116
CPN Water Works	0.106	0.151	0.180	0.207
Eastwood Village	0.177	0.205	0.215	0.233
Highland Lakes	0.006	0.006	0.006	0.007
Hood County Water Co.	1.367	1.776	2.006	2.245
Laguna Tres Estates	0.233	0.285	0.311	0.341
Laguna Vista Subdivision	0.168	0.225	0.258	0.292
Lipan Water Works	0.281	0.359	0.401	0.446
Long Creek Water Co.	0.107	0.140	0.158	0.177
Mesa Grande WSC	0.150	0.184	0.200	0.220
Montego Bay Estates	0.136	0.157	0.165	0.178
Mooreland Water Co.	0.128	0.148	0.156	0.168
North Fork Creek No II	0.152	0.176	0.185	0.199
Rain Water Supply Corp.	0.047	0.057	0.063	0.069
Resort Water	0.155	0.195	0.216	0.240
Ridge Utilities	0.184	0.277	0.342	0.400
Rock Harbor Estates	0.135	0.165	0.180	0.198
Rolling Hills Water Service	0.137	0.165	0.179	0.196
Sandy Beach Subdivision	0.176	0.203	0.214	0.231
Scenic View Estates	0.059	0.074	0.083	0.091
Shady Grove Subdivision	0.098	0.113	0.119	0.129
Shores Utility Corporation	0.085	0.099	0.104	0.112
Sky Harbour WSC	0.381	0.550	0.662	0.766
Thorp Springs Water	0.013	0.015	0.015	0.016
Western Hills Harbor	0.527	0.657	0.723	0.800
Whipponwill Bay Subdivision	0.267	0.309	0.324	0.350

Table 2-10 (continued)

Item	Projected			
	2000	2010	2020	2030
County Remainder (No Current Utility)				
Along NW Loop near Granbury	0.272	0.354	0.727	2.020
South of Hwy 377 at S. End of Loop	0.117	0.152	0.312	0.866
Infill between Granbury and Acton	0.233	0.304	0.623	1.731
Y Between Hwy 4 and Hwy 2580	0.047	0.061	0.125	0.346
Development East of Lake	0.047	0.061	0.125	0.346
Far NW	0.016	0.020	0.042	0.115
Far SW	0.016	0.020	0.042	0.115
Far NE	0.016	0.020	0.042	0.115
Far SE	0.016	0.020	0.042	0.115
Hood County Total	21.716	32.233	43.321	53.321
*Includes infiltration and inflows allowable.				

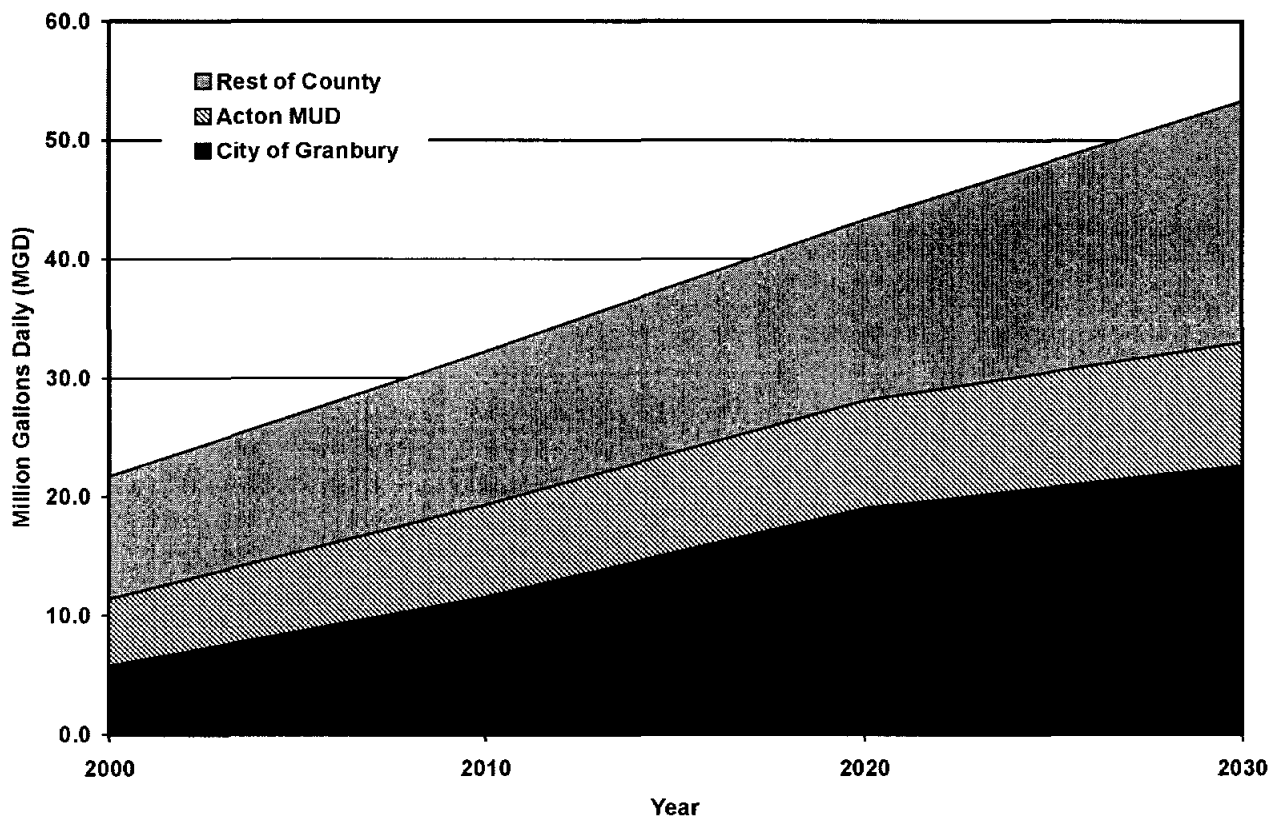

Figure 2-12. Peak Instantaneous Wastewater Flows Hood County High Case Population

(This page is intentionally left blank.)

Fig 2-13

Section 3

Existing Wastewater Facilities

3.1 General

Based on information from the Texas Natural Resource Conservation Commission (TNRCC), it appears that there are eight permits that involve wastewater systems serving municipal or residential wastewater systems in Hood County. The names of the wastewater permit holders are listed in Table 3-1. Locations of major existing facilities are shown in Figure 3-1.

Table 3-1.
Existing or Permitted Wastewater Treatment Facilities
Hood County Regional Wastewater System Feasibility Study

<i>Permit Number</i>	<i>Permit Holder</i>
0010178-002	City of Granbury, Southeast Plant ¹
0011208-001	Acton MUD, DeCordova Bend Plant ¹
0011265-001	City of Tolar ¹
0011415-001	Acton MUD, Pecan Plantation ¹
0013022-001	Hood County Utilities ¹
0013025-001	Ridge Utilities, Inc.
0013590-001	City of Lipan ¹
0013809-001	Fall Creek Utility Company
¹ Information from the permit file and/or information from the Owner of the Utility has been obtained.	

General permit information for the facilities is listed in Table 3-2. Site visits were made to the two Acton MUD wastewater treatment plants, the City of Granbury WWTP, the City of Tolar WWTP, and the City of Lipan WWTP. Contact was made with Hood County Utilities, but the Utility did not express an interest in the study. Information concerning the existing facilities is presented in the remainder of this section.

(This page is intentionally left blank.)

Fig 3-1
Foldout

**Table 3-2.
Existing or Permitted Wastewater Treatment Facilities
Hood County Regional Wastewater System Feasibility Study**

<i>Owner and/or Facility</i>	<i>Permit Parameters</i>			
	<i>Monthly Flow (MGD)</i>	<i>CBOD (mg/L)</i>	<i>TSS (mg/L)</i>	<i>NH₃ (mg/L)</i>
City of Granbury, Southeast WWTP ¹	2	10	15	3
Acton MUD, DeCordova Bend ²	0.24	10	15	3
City of Tolar	0.10	10	15	3
Acton MUD, Pecan Plantation ³	0.24	10	15	3
Hood County Utilities, Inc.	0.088	10	15	NA
City of Lipan	0.10	30	90	NA
Fall Creek Utility	Information not yet obtained			
¹ Plant expansion is currently underway to provide the permitted capacity listed. ² Plant is to be expanded to 0.375 mgd. Construction project underway at plant. ³ Plant is to be expanded to 0.39 mgd				

3.2 Wastewater Collection Systems

Areas with wastewater collection systems include portions of Acton MUD and essentially all of the Cities of Granbury, Tolar, and Lipan. The locations of these areas are shown in Figure 3-2.

Substantial developed areas do not currently have collection systems and treatment facilities and rely on on-site systems. Based on the estimated current population of Hood County and current flows to wastewater facilities, somewhere in the range of 50 percent of the population is not served by wastewater collection facilities.

3.3 Existing Wastewater Treatment Plants

3.3.1 City of Granbury Southeast Wastewater Treatment Plant

Granbury's Southeast WWTP is an activated sludge-type treatment plant that was originally built in 1986. Improvements to the plant are currently under construction to provide the plants' permitted capacity of 2.0 MGD. Average flow to the plant was 0.737 MGD during the 12 months ending September 1999.

(This page is intentionally left blank.)

Fig 3-2
Foldout

Treatment units at the plant prior to the start of the current construction project included headworks, lift station, aeration basin, secondary clarifiers, and chlorine contact chamber. Effluent is discharged to Lake Granbury. Waste sludge from the secondary clarifiers is periodically routed to drying beds for dewatering before being hauled to a landfill. The plant experiences a few problems. First, disk aerators are used to aerate the aeration basin and dissolved oxygen (DO) levels are sometimes too low. The City has experienced infiltration and inflow (I/I) into their sewer collection system and, as a result, they have had to report high instantaneous inflows on occasion.

Figure 3-3 is a conceptual layout of the Granbury WWTP that includes facilities currently under construction. Major changes to be made are the addition of an aerated grit removal system, two fine bubble aeration basins with air blowers (which will presumably solve low DO problems), a third secondary clarifier, a centrifuge for sludge dewatering; and the conversion of the existing aeration basin to an aerobic sludge digester with diffused air. Also, the plant will switch from chlorine disinfection to ultraviolet disinfection.

Overall, the City of Granbury's WWTP looks to be in good condition and capable of being used for an indefinite period into the future. However, the plant site is locked in, meaning no future expansions are possible.

3.3.2 Acton MUD – DeCordova Bend Wastewater Treatment Plant

Acton MUD's DeCordova Bend WWTP is an activated sludge-type treatment plant that is permitted for a flow of 240,000 gpd. Although Acton MUD does not record peak instantaneous flows, it is estimated that peak instantaneous flow to the facility is in the 450,000 to 500,000 gpd range.

As shown in the schematic in Figure 3-4, treatment consists of bar screens, an oxidation ditch with floating aerators, secondary clarifiers, a chlorine contact basin, and drying beds. Effluent is discharged to a creek and waste sludge is hauled to a landfill after dewatering.

DeCordova is currently under construction for expansion to 375,000 gpd capacity. The major improvement involves the addition of a second clarifier.

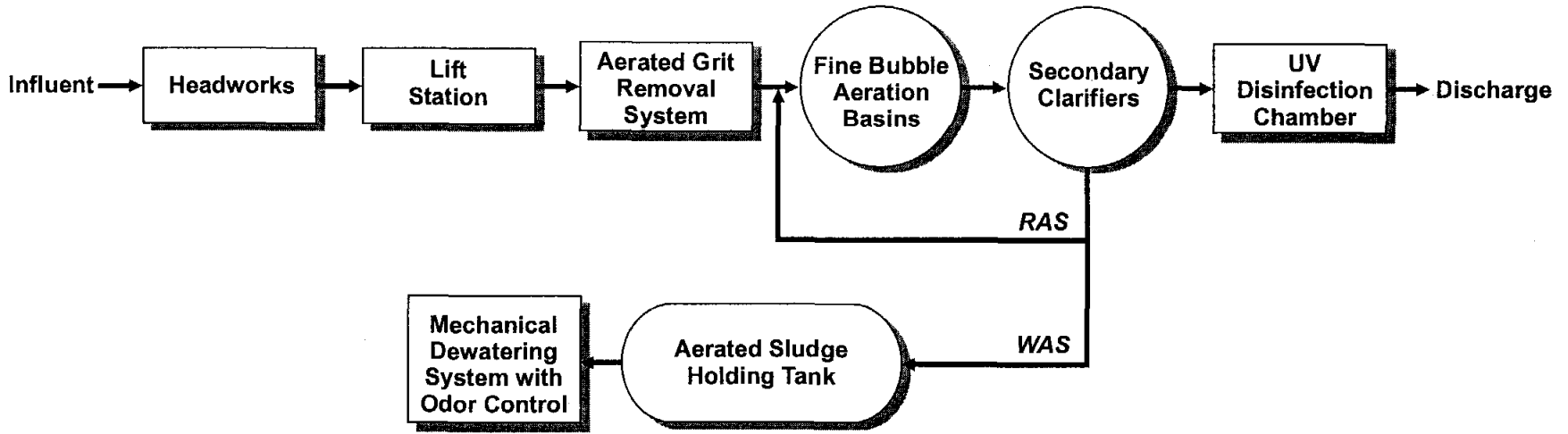

Figure 3-3. Schematic — City of Granbury WWTP

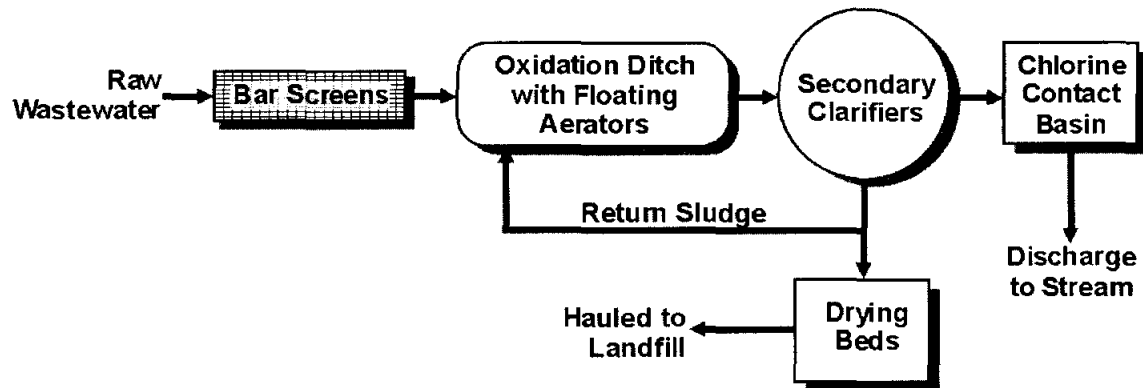

Figure 3-4. Schematic of DeCordova Bend Wastewater Treatment Plant

3.3.3 Acton MUD – Pecan Plantation Wastewater Treatment Plant

Acton MUD’s Pecan Plantation WWTP is quite similar to the DeCordova WWTP: it is an activated sludge-type treatment plant permitted for 240,000 gpd, with an estimated peak daily flow in the 450,000 to 500,000 gpd range. Also, as shown in the schematic in Figure 3-5, the Pecan Plantation WWTP has the same treatment processes as DeCordova, except that it does not have drying beds. Instead, sludge is routed to an open manhole before disposal to landfill. Effluent is discharged to the Brazos River. A proposed expansion to 390,000 gpd would consist of two new clarifiers, a second floating aerator in the oxidation ditch, and raising the wall height of the oxidation ditch.

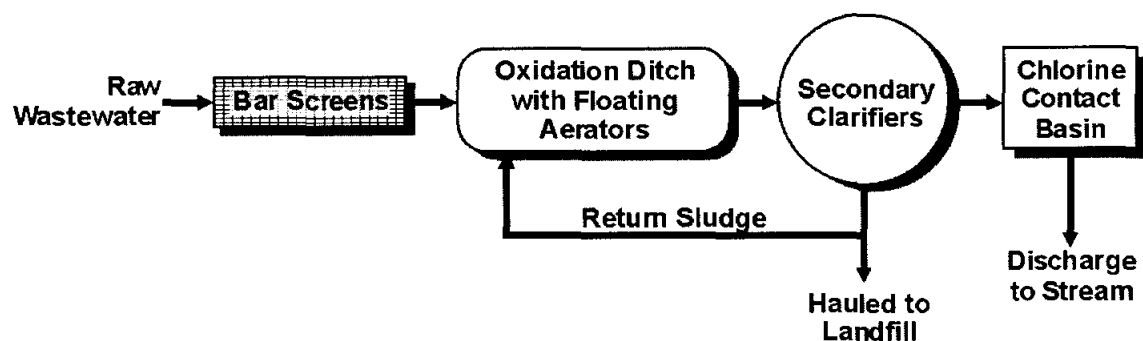

Figure 3-5. Schematic of Pecan Plantation Wastewater Treatment Plant

3.3.4 City of Tolar Wastewater Treatment Plant

The City of Tolar's WWTP is an activated sludge-type package plant permitted for a flow of 100,000 gpd. Average current flow is approximately 48,000 gpd. A schematic for the plant is shown in Figure 3-6.

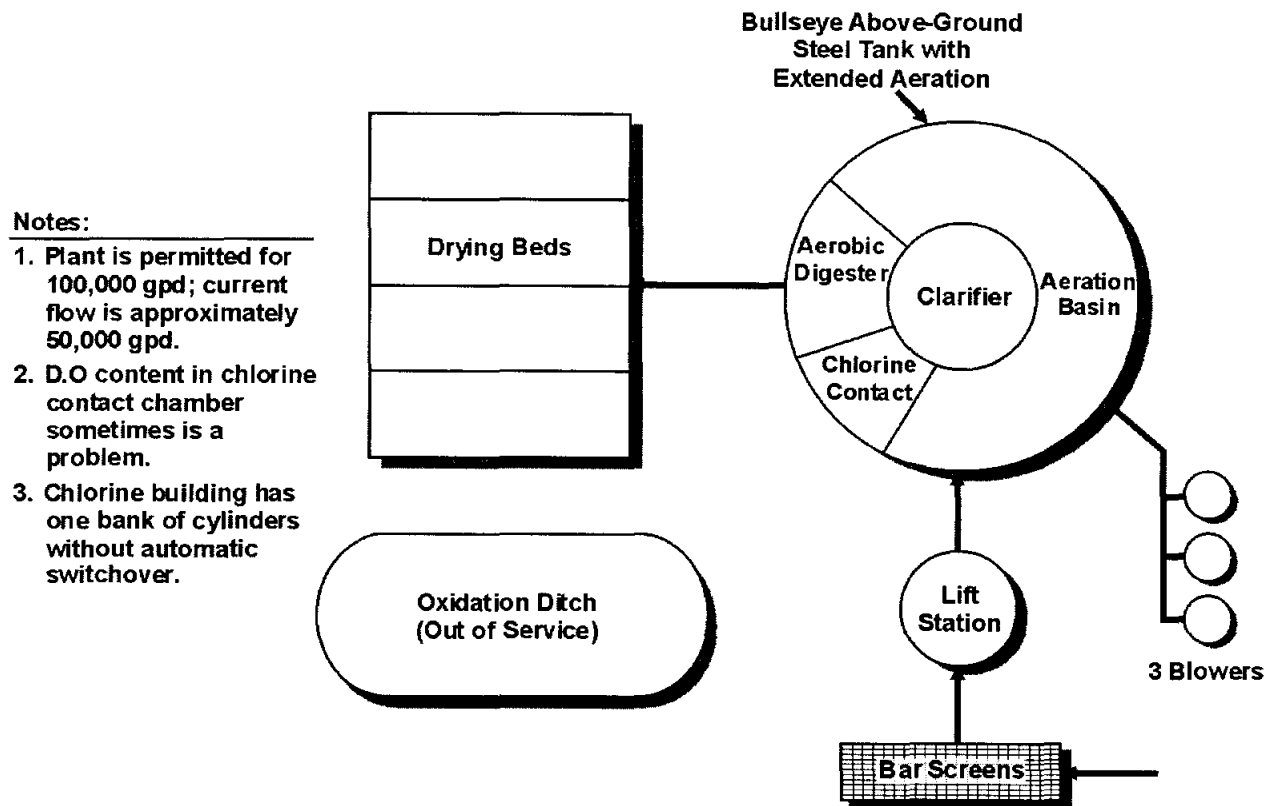

Figure 3-6. Schematic of City of Tolar's Wastewater Treatment Plant

The package plant uses on-site bar screens and a lift station. The wastewater treatment plant has an aeration basin, secondary clarifier, chlorine contact chamber, and aerobic digester in one unit. There is an oxidation ditch on the site that is not in service. Discharge is to a creek and sludge is wasted to drying beds. Influent has a high 5-day biochemical oxygen demand (BOD₅) and effluent tends to have low and inconsistent DO measurements. Tolar's WWTP could serve as a "regional" facility for growth within close proximity (about a 1-1/2 mile radius) of Tolar.

3.3.5 City of Lipan Wastewater Treatment Plant

The City of Lipan's WWTP is a stabilization pond-type plant permitted for a flow of 100,000 gpd. Average current flow is approximately 50,000 gpd. A plant schematic is shown in Figure 3-7 and reveals a fairly simple process: bar screens, aeration basin, and two stabilization ponds in series before effluent is pumped to a creek.

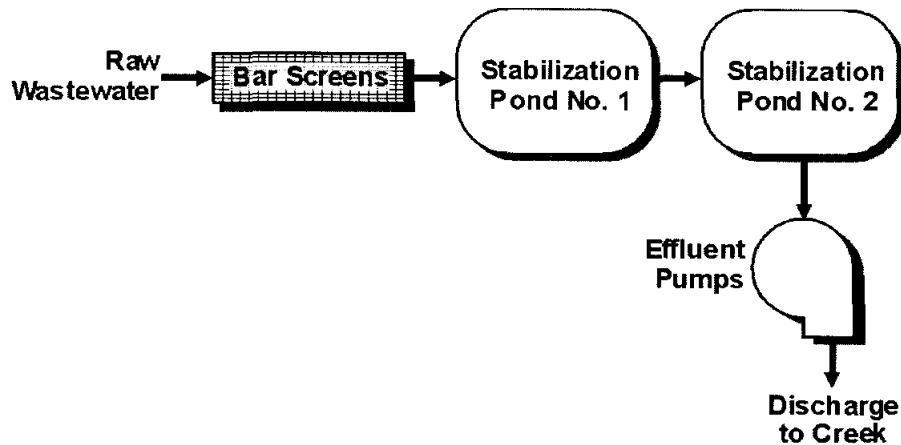

Figure 3-7. Schematic of City of Lipan's Wastewater Treatment Plant

The plant has historically had high pHs and has always been odor-free. Since Lipan is located in a remote area of Hood County, it is likely that their treatment plant would be used in the same capacity as the City of Tolar's WWTP: continue treating wastewater produced within the immediate surrounding areas instead of joining a county-area regional plan. It is possible, however, that the TNRCC may require conversion to a treatment process that produces a higher quality effluent if flows increase and effluent continues to be discharged.

3.3.6 Summary

Summary comments concerning the existing treatment facilities are listed below.

1. Existing collection systems currently convey wastewater to the treatment sites, so the sites will likely continue to function as treatment sites or pumping station sites for an indefinite future period.
2. Based on Owner input, the Acton MUD WWTP sites and the City of Granbury WWTP site are constrained, and no expansion beyond currently planned or permitted

capacity will be possible at the sites without land acquisition and significant permitting effort.

3. Following completion of the current expansion project at the City of Granbury WWTP, it appears that the plant will be capable of meeting current permit parameters for an extended time period.
4. The Acton MUD WWTPs provide relatively limited capacity, are aged, and are located in constrained sites. Replacement of the plants with capacity at other locations and decommissioning of the plants appears in order when economically feasible.

Section 4

Water Quality and Wastewater Treatment Requirements

4.1 General

4.1.1 Water Quality

There have been at least six studies of water quality in Lake Granbury since 1976. The Brazos River Authority has summarized the results for the studies; some of the important points of the studies are listed below.

- Nutrient concentrations in the lake generally do not comply with current Texas Natural Resource Conservation Commission (TNRCC) criteria.
- Shore-line concentrations of nutrients and tracer studies from soil absorption systems indicate the potential for transport of material from absorption fields into the lake.
- Nitrogen levels in the lake are generally increasing.
- Water quality in coves appears to be determined by surrounding land use rather than by quality of water in the lake.

Generally, the past studies justify concern regarding the use of on-site septic tanks and absorption fields, and regarding water quality in Lake Granbury.

4.1.2 Wastewater Treatment Requirements — General

Minimum wastewater treatment requirements applicable to wastewater treatment plants in Texas are established by the TNRCC. The TNRCC issues wastewater discharge permits to entities with wastewater treatment facilities under the provisions of Chapter 317 of their regulations. TNRCC wastewater discharge permits define the allowable flows that a facility may treat (monthly average and peak instantaneous), and the quality of effluent that the facility is required to produce.

Individual entities may choose to treat wastewater to a higher level than is required by the TNRCC, but treatment to a lower level than is required by the TNRCC is a violation of the permit and is against the law. The TNRCC has enforcement powers that allow them to take enforcement actions and to assess fines when permit conditions are not met.

Wastewater discharge permits may be written for discharge or no-discharge conditions. Permits written for discharge and for no-discharge situations both define effluent quality requirements and allowable flows. No-discharge permits are typically applicable to land

disposal (irrigation) operations, and require that effluent storage facilities be provided so that effluent may be stored when conditions (weather or other) are such that disposal operations can not use effluent at the rate at which it is produced.

The TNRCC also has provisions that allow for use of reclaimed water (treated effluent from a wastewater treatment plant). Use of reclaimed water is covered under the provisions of Chapter 210 of the TNRCC regulations rather than in the wastewater discharge permit. Use of reclaimed water differs from a no-discharge operation in that no-discharge operations must use all plant effluent, while Chapter 210 regulations for reclaimed water dictate that provision of reclaimed water is on the basis of user demand. Thus, a plant must be permitted to discharge the entire plant flow even if a portion of the plant effluent is to be used as reclaimed water under Chapter 210 Regulations, because use is on a demand basis, and the entire plant flow may legally be discharged at any given time.

4.2 Wastewater Discharge Requirements

4.2.1 Plants Discharging to a Receiving Water

The TNRCC establishes effluent requirements for wastewater treatment plants on a case by case basis. Effluent requirements are based on stream conditions (historical low flows, downstream uses of the stream, aquatic life in the stream, and other pertinent factors) and characteristics of the wastewater (primarily the permitted flow for most municipal wastewaters).

Effluent parameters for municipal wastewaters are currently intended to reduce the level of materials in the wastewater that would result in excessive dissolved oxygen reduction in the receiving water (with attendant adverse effect on aquatic life), to provide a suspended solids concentration that does not have an adverse aesthetic or biological effect, and to minimize pathogenic organisms in the effluent. For municipal wastewaters, the major effluent parameters that are currently in most discharge permits and that generally control design of treatment facilities are:

1. Carbonaceous biochemical oxygen demand (CBOD);
2. Ammonia nitrogen concentration (NH₃);
3. Total suspended solids (TSS);
4. Dissolved oxygen concentration (DO); and
5. Disinfection by providing a residual chlorine concentration of not less than 1 mg/L after 20 minutes (or a comparable process).

Some wastewater discharge permits in Texas also have limits on phosphorous. In the future, it is likely that more discharge permits will include effluent phosphorous limits, and they may also include limits on total nitrogen. Both phosphorous and nitrogen have impacts on algal growth in streams and lakes.

Effluent requirements associated with any wastewater treatment plant improvements or new plants must be coordinated with the TNRCC. Based on the characteristics of the study area (primarily growth and receiving water use), it is our recommendation that plans for any wastewater treatment facility improvements or for new facilities that are to discharge to the Brazos River or its tributaries should initially involve provision for treatment to at least the current levels that are listed in Table 4-1, unless the TNRCC indicates that more stringent parameters will be required. The Acton MUD plants, the Granbury WWTP, and the Tolar WWTP currently are permitted at the effluent levels listed in the Current Requirement or Recommended Design Value column of Table 4-1.

Table 4-1 also includes recommended effluent levels for no-discharge systems and for potential future permit requirements. Facility master plans and layouts should also include provisions for upgrading to the potential future requirement levels that are listed in Table 4-1. A schematic indicating ultimate wastewater facilities that should be considered when planning and laying out treatment facilities is shown in Figure 4-1.

4.2.2 No-Discharge Systems

As indicated in the previous paragraph, no-discharge systems generally involve use of effluent for irrigation and require that storage be provided so that effluent is not discharged during periods when effluent cannot be used for irrigation. Effluent is normally used for irrigation of golf courses or agricultural land. In Hood County, golf courses would be a likely candidate for use of effluent from the larger treatment facilities.

Storage facilities for no-discharge systems usually must provide sufficient volume to store the permitted plant flow for at least 90 days. Storage facilities must be lined with synthetic liners or the bottom must have a low permeability that complies with TNRCC criteria. Permeability and volume requirements result in fairly expensive storage systems.

Table 4-1.
Selected Current and Anticipated Effluent Design Requirements
Hood County Regional Wastewater System Feasibility Study

<i>Item</i>	<i>Current Requirement or Recommended Design Value</i>	<i>Potential Future Requirement or Recommended Design Value</i>
Discharge Systems		
CBOD	10 mg/L	5 mg/L – Recommended
TSS	15 mg/L	5 mg/L – Recommended
NH ₃	3 mg/L	2 mg/L – Recommended
P	Not Applicable	1 mg/L – Recommended
Residual Chlorine,	Residual Cl ₂ ≥ 1 mg/L	Residual Cl ₂ ≥ 1 mg/L
Dissolved Oxygen	≥ 4 mg/L	≥ 4 mg/L
No-Discharge System (Areas Accessible to Public)		
CBOD ¹	10 mg/L – Recommended	5 mg/L – Recommended
TSS ¹	15 mg/L – Recommended	5 mg/L – Recommended
NH ₃	2 mg/L – Recommended	2 mg/L – Recommended
P	Not Applicable	Not Applicable
Residual Chlorine	≥ 1 mg/L	May change to allowable coliform concentration
¹ TNRCC allows higher CBOD and TSS values for use of effluent on controlled access areas, such as golf courses, or a dedicated land disposal area. Values listed are recommended if disposal is on any publicly accessible area, however.		

Effluent requirements for storage systems in no-discharge systems are dependent on the end use of the effluent. For golf course irrigation, the TNRCC has historically approved effluent requirements of 20 mg/L for both BOD and TSS. Recommended effluent values for disposal of effluent on publicly accessible areas such as golf courses are listed in Table 4-1. The recommended values listed in Table 4-1 are somewhat more stringent than might be permitted by the TNRCC, but, in our opinion, are indicative of the minimum quality that should be used on publicly accessible areas.

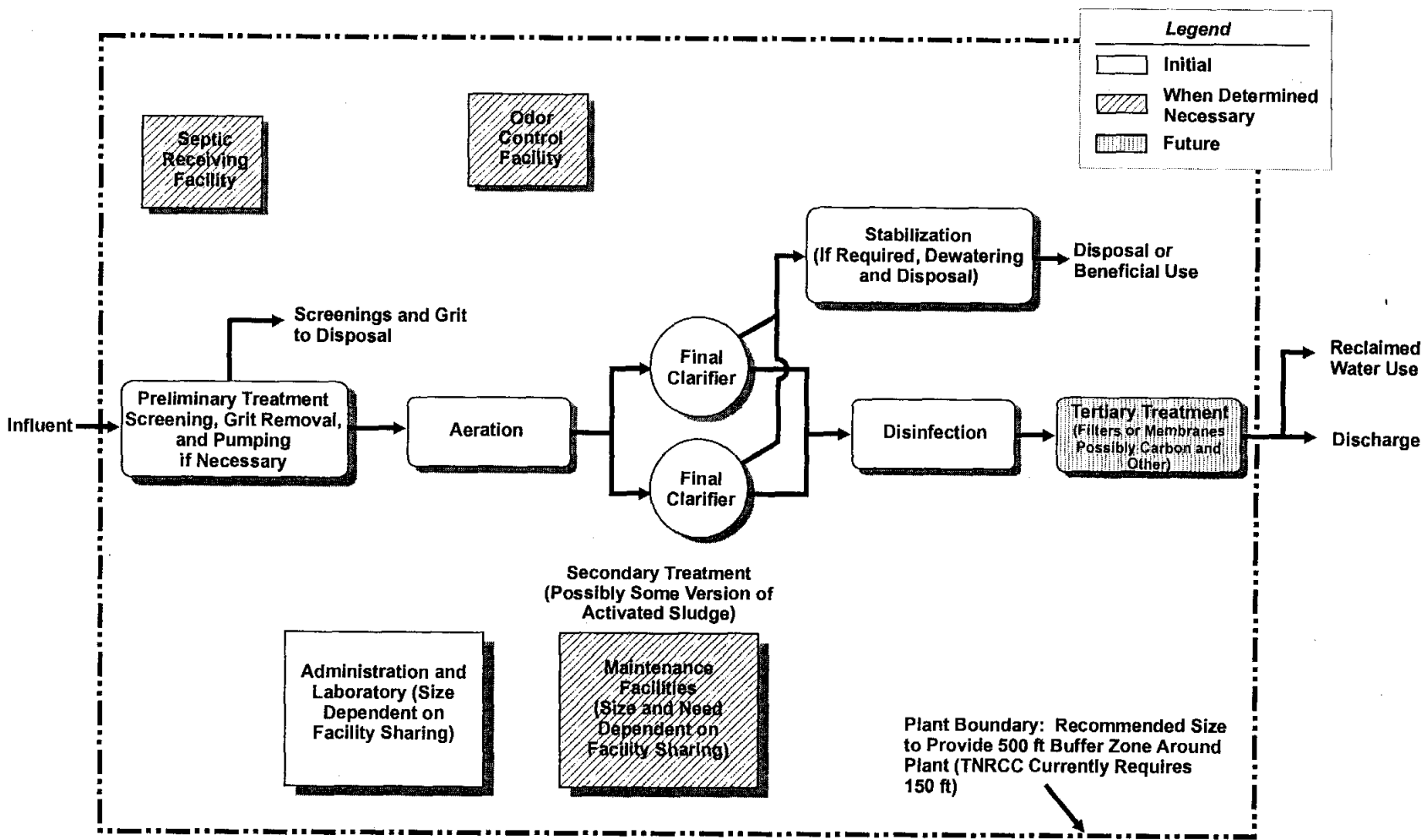

Figure 4-1. Conceptual Schematic / Ultimate Wastewater Treatment Facilities

4.3 Use of Reclaimed Water

Use of treated effluent for irrigation of agricultural land, golf courses, and other areas such as roadway medians is a fairly common practice. Additionally, school systems in other states use reclaimed water for irrigation of grounds and athletic fields, and some school systems in Texas are in the process of implementing such use. Further, reclaimed water use is actively promoted as a good water management strategy by the State of Texas. In Texas, the TNRCC has two sets of regulations under which such use can be approved; the two sets of regulations were mentioned in Section 4.1 and are described in Table 4-2.

**Table 4-2.
Summary Information
TNRCC Regulations Regarding Use of Treated Wastewater
Hood County Regional Sewerage System Feasibility Study**

TNRCC Regulations	Comments
Chapter 210	1. Allows use of treated wastewater on a demand, or as needed basis
	2. Because use is on an as-needed basis, the wastewater discharge permits allowable flow, and thus the permitted capacity, must be for the full expected flow.
	3. The TNRCC has different sets of effluent requirements for different uses of the effluent.
	4. TNRCC approval is by means of a notification procedure, which tends to be fairly routine for most projects.
	5. Storage facilities are not required other than for operational requirements, and implementation costs usually only involve the cost of conveyance facilities.
Land Disposal (irrigation) Chapter 317	1. Amount of effluent going to land disposal is identified in permit, and the permitted discharge flow may be the total flow minus the amount of effluent going to land disposal.
	2. TNRCC approval for new systems involves a major amendment of the wastewater discharge permit, which can be a lengthy and expensive procedure.
	3. Effluent storage is required to ensure that effluent permitted for land disposal is not discharged during periods when land application is not possible. Storage facilities can be expensive.

Chapter 317 use of treated wastewater is not normally economically feasible except in cases where discharged effluent must be treated to a very high level, or where discharge is not an acceptable option. Chapter 210 reuse of treated effluent is often economically feasible and opportunities for such reuse should be explored in Hood County on an ongoing basis, particularly with the number of golf courses in the area. It is difficult to project the impact that use of reclaimed water could have on future water supply needs since use of reclaimed water has not been evaluated thoroughly, but reuse does have the potential to reduce water needed for supply. Additionally, reuse of effluent is normally greatest in the summertime when stress on supply, treatment, and conveyance facilities is greatest.

Industrial use of reclaimed water is also common. A power plant is currently planned in south Hood County and presents a potential opportunity for use of reclaimed water.

The locations of golf courses and the proposed power plant are shown in Figure 4-2. Information concerning the golf courses located in the Granbury area is listed in Table 4-3. Water demands shown for the golf courses are based on generalized water use data for golf courses in Texas, and are intended to provide an indication as to the amount of water that is used for golf course irrigation. The average use is based on the golf courses being overseeded with rye in the winter, and irrigation of the rye at a relatively low rate in the winter.

Table 4-3 indicates that golf course irrigation in the study area could use an estimated 5 MGD on an annual average basis. Use of reclaimed water for irrigation would increase the amount of water available for other uses. Use of reclaimed water would likely be more expensive than the source of water used for golf course irrigation because reclaimed water would have to be pumped and conveyed to each point of use. The unit cost of the reclaimed water, though, will almost certainly be less than the unit cost of developing a new water source.

If reclaimed water use is to be implemented, the golf courses will likely be a major user of reclaimed water, and will likely provide the basis for development of a reclaimed water distribution system. The two TNRCC Chapter 210 categories for reclaimed water are Type 1 and Type 2, with Type 1 having the higher quality requirements. Reclaimed use applications in which public contact with the water is anticipated are included in the TNRCC Type 1 category, and other uses generally fall under the Type 2 category. Quality requirements for Type 1 and Type 2 waters are listed in Table 4-4.

(This page is intentionally left blank.)

Foldout Fig 4-2

**Table 4-3.
Granbury Area Golf Courses**

<i>Golf Course</i>	<i>Number of Holes</i>	<i>Irrigation Source</i>	<i>Estimated Average Use (MGD)</i>	<i>Estimated Peak Use (MGD)</i>
DeCordova Bend Estates	9	Raw Water	0.3	0.5
Granbury Country Club	9	Raw Water	0.3	0.5
Hidden Oaks	18	(Not Provided)	0.55	1.0
The Nutcracker Golf Club	18	(Not Provided)	0.55	1.0
Pecan Plantation County Club	18	Raw Water	0.55	1.0
Starr Hollow	9	(Not Provided)	0.3	0.5
Three Oaks Golf Course	9	(Not Provided)	0.3	0.5

Type 2 reclaimed water has been approved for golf course irrigation and is currently used for golf course irrigation at locations in Texas. If a reclaimed water system is installed to serve golf courses in the Granbury area, the feasibility of treating to Type 1 quality should be evaluated, as treatment to Type 1 standards would allow the system to also serve parks, schools, and other potential users.

**Table 4-4.
TNRCC Chapter 210 Type 1 and Type 2 Quality Requirements
Regarding Use of Reclaimed Water
Hood County Regional Sewerage System Feasibility Study**

<i>Item</i>	<i>Type 1</i>	<i>Type 2 (from other than a pond system)</i>
CBOD, mg/L	5	15
Turbidity, NTU	3	N/A
Fecal Coliform Geometric mean	20	200
Fecal Coliform, CFU/100/ml Not to Exceed, CFU/100 ml	75	800

4.4 Summary

Information and recommendations presented in this Section are summarized by listing below.

1. Design effluent requirements for any wastewater treatment plant projects should be coordinated with the TNRCC. For purposes of this study, we recommend that plans and costs for any wastewater facilities be based on the current effluent requirements listed in Table 4-1 (which includes $\text{CBOD} \leq 10 \text{ mg/L}$, $\text{TSS} \leq 15 \text{ mg/L}$, and $\text{NH}_3 \leq 2 \text{ mg/L}$), and that all facilities be planned and space allocated for future upgrade to the future requirements listed in Table 4-1 (which involve filtration and nutrient removal).
2. Potential uses of reclaimed water in Hood County should be explored, and where applicable, use of reclaimed water should be evaluated.
3. If use of reclaimed water is implemented, it appears that Type 1 water (the TNRCC category with higher quality water) should be evaluated, as Type 1 water would allow more potential uses of the water.

Section 5

Wastewater Alternatives

5.1 General

Regional wastewater options considered in this study are generally based on these planning assumptions:

- The City of Granbury WWTP will continue in service at the permitted capacity of 2 MGD.
- The Acton MUD wastewater treatment plants will be phased out over time, due to site constraints and age of the facilities. The Acton MUD wastewater treatment plant sites will serve as lift station sites when the plants are phased out, and the phase-out schedule for the plants will be dictated by economics.
- Development in the area around the City of Tolar (within 1-1/2 miles plus or minus) will be served at the City of Tolar WWTP site.
- Development in the area of Lipan (within 1-1/2 miles plus or minus) will be served at the City of Lipan WWTP site.
- Existing developed areas without sewer service around Lake Granbury and the high population growth forecast for the areas adjacent to the proposed northwest loop around Granbury, near the area around the intersection of Highways 144 and 377, along Highway 377 east of Granbury, and around Acton MUD will be served by the existing City of Granbury Plant and by the new treatment facilities.
- Facility capacities and estimated costs for Alternatives 1 through 5 described below are based on high population projections. Alternative 6 is based on land acquisition and conveyance facility capacities sized to handle on high population projections, but plant capacities to handle SB-1 projections. Conveyance facilities and land acquisition are based on high population projections because both would be difficult to increase.

Local entities understand that any funding from TWDB administered programs must be based on capacities determined by approved TWDB projections at the time of funding. Any capacity in excess of that to meet requirements of approved TWDB projections at the time of funding will be funded by local entities.

Based on the planning assumptions above, the area around the City of Granbury and Acton MUD was divided into four service areas, and six alternative treatment and associated collection options were developed to serve existing areas without sewer service and the high growth areas. The six treatment and collection alternatives are listed below and are described in more detail in the following sections. The service area boundaries are delineated in Figures 5-1 to 5-6, but generally involve the areas separated by the intersections of the Brazos River/Lake Granbury and US 377. Locations of facilities shown in Figures 5-1 through 5-6 are intended to

indicate the General area in which facilities would be located. Final location will be determined through detailed studies that include costs and projected impacts of facility location on land use.

- Alternative 1. The existing City of Granbury WWTP plus plants in each of the four service areas (Figure 5-1).
- Alternative 2. The existing City of Granbury WWTP plus plants in three of the four service areas (Figure 5-2).
- Alternative 3. The existing City of Granbury WWTP plus plants in two of the four service areas (Figure 5-3).
- Alternative 4. The existing City of Granbury WWTP plus plants in one of the four service areas (Figure 5-4).
- Alternative 5. The existing City of Granbury WWTP plus plants in two of the four service areas (Figure 5-5). Alternative 5 differs from Alternative 3 in plant location.
- Alternative 6. Same as Alternative 5 except that plants will initially be sized based on SB-1 population projections. Land at plant sites will be adequate to accommodate plants and sized for high population projections and conveyance facilities will be sized to handle flows from high population projections.

Alternative 4 provides the most centralized, and regionalized, of the four systems.

5.2 Wastewater Treatment and Collection System Alternatives

Six wastewater treatment and collection system alternatives for Hood County were developed for this study. As part of this process, the county was split into four wastewater collection drainage areas based on Lake Granbury and the location of natural ridgelines. The resulting drainage areas were labeled arbitrarily as Areas A, B, C, and D, and are shown in Figure 5-1, which also shows Alternative 1 as discussed in Section 5.2.1. Area A would serve the northwest portion of the county. Area B would serve the northern area of Hood County west of Lake Granbury, including the Laguna Vista and Sky Harbor developments. Area C would serve the eastern portion of the county between Lake Granbury and Highway 377, including a large portion of Acton MUD's service area. Lastly, Area D is the largest of the four drainage areas and would serve the southern part of the county and the western part of the City of Granbury, which is currently served by the City's existing treatment plant. It is anticipated that the existing Granbury WWTP would treat sewage collected east of Lake Granbury only, thereby allowing the City to abandon the existing force main that crosses the lake from the western part of town.

For each alternative, a regional collection system was developed that consists of major lift stations with corresponding force mains and gravity sewer lines. Preliminary design of lift stations and force mains was based on 2020 peak daily flows, and a maximum force main

FIG 5-1
Foldout

Fig 5-2
Foldout

Fig 5-3
Foldout

Fig 5-4
Foldout

Fig 5-5
Foldout

Fig 5-6
Foldout

velocity of 4 feet per second. Gravity sewer lines were designed based on 2020 instantaneous peak flows. A handful of major highway crossings would be required for each alternative.

5.2.1 Alternative 1 — City of Granbury Wastewater Treatment Plant plus Four Others

Alternative 1 proposes a total of five treatment plants for the regional system: the existing Granbury WWTP plus four new plants, one in each of the four drainage areas. Plant A, located in the Stroud Creek area, would serve Area A and have a 2020 peak monthly flow rating of 3.50 MGD. Plant B, located next to Bee Creek, would serve Area B and have a peak monthly flow rating of 1.05 MGD. Plant C, located in the Fall Creek area, would serve Area C and have a peak monthly flow rating of 3.17 MGD. Lastly, Plant D, located near the intersection of Highway 2425 and Wolf Hollow Court, would serve Area D and have a peak monthly flow rating of 6.89 MGD. A layout of Alternative 1 is shown in Figure 5-1.

5.2.2 Alternative 2 — City of Granbury Wastewater Treatment Plant plus Three Others

Alternative 2 proposes a total of four treatment plants for the regional system: the existing Granbury WWTP plus three new plants. Plants A and D would remain unchanged from their respective Alternative 1 configurations. Under this alternative, Plant B would not exist, as Plant C would serve Areas B and C and have a peak monthly flow rating of 4.22 MGD. A layout of Alternative 2 is shown in Figure 5-2.

5.2.3 Alternative 3 — City of Granbury Wastewater Treatment Plant plus Two Others

Alternative 3 proposes a total of three treatment plants for the regional system: the existing Granbury WWTP plus two new plants. As with Alternative 2, Plant C would serve Areas B and C and have a peak monthly flow rating of 4.22 MGD. Plant D, proposed as the second new plant, would serve Areas A and D and have a peak monthly flow rating of 10.39 MGD. A layout of Alternative 3 is shown in Figure 5-3.

5.2.4 Alternative 4 — City of Granbury Wastewater Treatment Plant Plus One Other

Alternative 4 proposes a total of only two treatment plants for the regional system: the existing Granbury WWTP plus one new regional plant. Plant D is proposed as the regional plant for this alternative and is intended to serve the entire county with a peak monthly flow rating of

14.61 MGD. A layout of Alternative 4 is shown in Figure 5-4. Unlike with the previous three alternatives, this alternative would require two new lake and/or river crossings.

5.2.5 Alternative 5 — City of Granbury Wastewater Treatment Plant plus Two Others

Similar to Alternative 3, Alternative 5 proposes a total of three treatment plants for the regional system: the existing Granbury WWTP plus two new plants: Plants A and D. Plant A would serve Area A and have a peak monthly flow rating of 3.50 MGD. Plant D would serve Areas B, C, and D and have a peak monthly flow rating of 11.11 MGD. A layout of Alternative 5 is shown in Figure 5-5.

Table 5-1 summarizes treatment plants and service areas for each of the alternatives.

5.2.6 Alternative 6 — City of Granbury Wastewater Treatment Plant Plus Two Others

As indicated earlier in this section, Alternative 6 is similar to Alternative 5. The difference between the two alternatives involves plant capacities. Plant capacities in Alternative 5 are based on high population projections, and capacities in Alternative 6 were based on SB-1 population projections to reduce costs. Conveyance system capacities and land sizes for plant sites in both alternatives are based on high population projections. A layout of Alternative 6 is shown in Figure 5-6.

**Table 5-1.
Treatment Plant Scenarios for all Alternatives¹**

Alternative	Proposed WWTP	Service Area	Year 2020 Monthly Peak Flow (MGD)
1	A	A	3.50
	B	B	1.05
	C	C	3.17
	D	D	6.89
2	A	A	3.50
	C	B and C	4.22
	D	D	6.89
3	C	B and C	4.22
	D	A and D	10.39
4	D	all	14.61
5	A	A	3.50
	D	B, C, and D	11.11
6	A	A	0.94
	D	B, C, D	6.26
¹ Flow of 1.83 MGD from Granbury in Area 'C' is assumed to be treated by City of Granbury's existing WWTP.			
² Collection systems for Alternatives 5 and 6 are the same. Plant capacities for Alternative 5 are based on high population and plant capacities for Alternative 6 are based on SB-1 population projections.			

5.3 Estimated Costs of Alternatives

Preliminary cost estimates for pipeline easements, treatment plant and lift station land acquisition, collection and treatment system construction, and system operation and maintenance (O&M) were developed for each alternative. In short, total annualized costs for the six alternatives do not differ significantly from one another, and as such, selection of an alternative should not be based on costs alone. Other factors such as sewerage phasing for developments, areas of anticipated high growth within the county, and the importance of a reclaimed water system, as examples, should be carefully thought out before a regional sewerage plan is chosen. Discussion and tables summarizing and explaining the costs follow.

5.3.1 Capital Costs

Capital costs were split into two areas: easement and land acquisition costs and construction costs. Assumptions and methodology used for easement and land acquisition costs are as follows:

1. Pipeline easements: \$1.50 per linear foot of 30-foot-wide access easement where force mains and sewer lines are adjacent to roadways.
2. Land for lift stations: \$10,000 per acre, 250-foot square tract per lift station, 23 lift stations for each alternative.
3. Land for treatment plants: \$5,000 per acre with a 500-foot buffer on all sides of plants, and interpolation and extrapolation of existing treatment plant tract sizes.

These costs, shown in Table 5-2, reveal that Alternative 4 requires a slightly higher quantity of easements, and as expected, Alternative 1 tops all other alternatives for cost of treatment plant land since four new plants are proposed under said option. Lift station land costs are identical for each alternative due to a constant number of lift stations from one alternative to the next. As expected, easement and land costs for Alternative 6 match those for Alternative 5 since both alternatives have the same easement and land requirements.

**Table 5-2.
Easement and Land Costs**

<i>Item</i>	<i>Alternative 1</i>	<i>Alternative 2</i>	<i>Alternative 3</i>	<i>Alternative 4</i>	<i>Alternative 5</i>	<i>Alternative 6</i>
Pipeline Easements	\$151,000	\$155,000	\$154,000	\$162,000	\$162,000	\$162,000
Land for Lift Stations	330,000	330,000	330,000	330,000	330,000	330,000
Land for Treatment Plants	<u>1,171,000</u>	<u>984,000</u>	<u>797,000</u>	<u>611,000</u>	<u>797,000</u>	<u>797,000</u>
Total	\$1,652,000	\$1,469,000	\$1,281,000	\$1,103,000	\$1,289,000	\$1,289,000

Assumptions and methodology used in the determination of construction costs are as follows:

1. Treatment plants: linear interpolation between \$4.00 per gallon per day for 1 MGD capacity and \$3.25 per gallon per day for 10 MGD capacity, with the exception of Alternative 4 (~14 MGD) = \$2.75 per gallon per day.
2. Lift stations: a cost curve from “Wastewater Management Plan, Colorado River and Tributaries, Texas” report was used given flow and head requirements for each lift station, and adjusted to present-day dollars using the current *Engineering News Record (ENR)* cost index.

3. Force mains: \$3.75 per inch in diameter per linear foot.
4. Gravity sewers: unit costs were developed using current RS Means cost data.

As shown in Table 5-3, capital costs for treatment plants expectedly drop going from Alternative 1 (four new plants) to Alternative 4 (one new plant). Due to the higher accumulation of sewage flows near Alternative 4's Plant D, which require higher horsepower at lift stations and larger pipe sizes for the force mains and gravity sewers, capital costs for the three aforementioned items are higher for said alternative. However, total construction costs yield a lower dollar amount for Alternative 4. Cost of construction for Alternate 6 treatment plants and lift stations are significantly lower since unit sizing was based on lower population projections.

**Table 5-3.
Construction Costs**

<i>Item</i>	<i>Alternative 1</i>	<i>Alternative 2</i>	<i>Alternative 3</i>	<i>Alternative 4</i>	<i>Alternative 5</i>	<i>Alternate 6</i>
Treatment Plants	\$53,755,000	\$53,199,000	\$49,518,000	\$40,180,000	\$49,380,000	\$26,070,000
Lift Stations	30,011,000	32,988,000	32,988,000	37,780,000	36,961,000	22,770,000
Force Mains	10,931,000	11,469,000	12,289,000	12,210,000	11,896,000	11,896,000
Gravity Interceptors	2,085,000	2,905,000	2,947,000	3,941,000	3,910,000	3,910,000
Total	\$96,782,000	\$100,561,000	\$97,742,000	\$94,111,000	\$102,147,000	\$64,646,000

Total capital costs for each alternative are shown in Table 5-4. The "Contingencies and Miscellaneous" consist of contingencies (20 percent of capital cost subtotal), engineering (15 percent for Alternatives 1-5; 13 percent for Alternative 6), surveying (5 percent), testing (5 percent), administration (4 percent for Alternatives 1-5; 2 percent for Alternative 6), and resident project representative (5 percent for Alternatives 1-5; 4 percent for Alternative 6). The capital cost grand total was converted into an annual cost assuming a 20-year payment recovery period with a 6 percent interest rate. These costs assume a complete regional sewerage and collection system and do not consider a construction phasing plan, which will help reduce start-up costs associated with this regional sewerage system since most areas will not initially be provided with sewerage service. A five-step phasing plan is illustrated in Figure 5-7 and a breakdown of capital costs for this phasing plan is tabulated under Appendix A.

**Table 5-4.
Summary of Capital Costs**

<i>Item</i>	<i>Alternative 1</i>	<i>Alternative 2</i>	<i>Alternative 3</i>	<i>Alternative 4</i>	<i>Alternative 5</i>	<i>Alternative 6</i>
Total Capital Costs	\$98,400,000	\$102,000,000	\$99,000,000	\$95,200,000	\$103,400,000	\$65,900,000
Contingencies and Misc.	<u>53,200,000</u>	<u>55,100,000</u>	<u>53,500,000</u>	<u>51,400,000</u>	<u>55,900,000</u>	<u>32,300,000</u>
Grand Total	\$151,600,000	\$157,100,000	\$152,500,000	\$146,600,000	\$159,300,000	\$98,200,000
Annual Debt Service ¹	\$13,217,000	\$13,697,000	\$13,296,000	\$12,781,000	\$13,888,000	\$8,562,000
¹ 20-year recovery period with a 6 percent interest rate.						

5.3.2 Operation and Maintenance Costs

Annual costs for the operation and maintenance of proposed treatment plants, collection systems, and lift stations were developed for each alternative and are shown in Table 5-5. Assumptions and methodology used in the determination of annual O&M costs are as follows:

1. Treatment plants: costs are based upon a logarithmic equation developed from HDR recorded and study data.
2. Collection system: \$5,000 per year per mile of sewer pipe, based on an HDR benchmarking study.
3. Lift stations: \$5,000 labor per lift station per year and \$2,000 equipment and materials per lift station per year, plus pumping costs based on horsepower requirements, 60 percent efficiency, operation rate of 25 percent on/75 percent off for 2020 instantaneous peak flows, and an energy rate of \$0.08 per kilowatt-hour.

**Table 5-5.
Annual O&M Costs**

<i>Item</i>	<i>Alternative 1</i>	<i>Alternative 2</i>	<i>Alternative 3</i>	<i>Alternative 4</i>	<i>Alternative 5</i>	<i>Alternative 6</i>
Treatment Plants	\$3,525,000	\$3,422,000	\$3,136,000	\$2,756,000	\$3,104,000	\$1,954,000
Interceptors and Force Mains	274,000	294,000	281,000	275,000	288,000	288,000
Lift Stations	<u>699,000</u>	<u>726,000</u>	<u>735,000</u>	<u>839,000</u>	<u>758,000</u>	<u>591,000</u>
Total	\$4,498,000	\$4,442,000	\$4,152,000	\$3,870,000	\$4,150,000	\$2,833,000

Table 5-5 shows that Alternative 1 has higher O&M costs due to a higher number of proposed treatment plants. Alternative 6 has significantly lower O&M costs than all other alternatives.

Figs 5-7
Foldout

Annual O&M costs were combined with the debt service for capital costs to generate a figure for total annual costs for each alternative. These total annual costs, shown in Table 5-6, reveal that Alternative 6 is by far the least-expensive alternative and that the other five alternatives vary no more than 10 percent from each other.

Table 5-6.
Total Annual Costs

<i>Item</i>	<i>Alternative 1</i>	<i>Alternative 2</i>	<i>Alternative 3</i>	<i>Alternative 4</i>	<i>Alternative 5</i>	<i>Alternative 6</i>
Debt Service for Capital Costs	\$13,217,000	\$13,697,000	\$13,296,000	\$12,781,000	\$13,888,000	\$8,562,000
O&M Costs	<u>4,498,000</u>	<u>4,442,000</u>	<u>4,152,000</u>	<u>3,870,000</u>	<u>4,150,000</u>	<u>2,833,000</u>
Total	\$17,715,000	\$18,139,000	\$17,448,000	\$16,651,000	\$18,038,000	\$11,395,000

5.4 Collection in Existing Developed Areas

Section 5.3 presented information concerning alternate means of providing the main wastewater collection system that would receive flow from existing and future subdivisions and other developments in the study area, and the costs of the alternate means of providing the main collection system. Section 5.3 did not address the systems within existing or future subdivisions or other developments that would convey wastewater to the main collection systems. Such systems would be common to all alternatives and if the associated costs were included for each alternative under Section 5.3, the cost differences between the alternatives would have been dampened.

Section 5.4 presents information concerning proposed collection systems within existing developed areas that would convey wastewater to the main collections systems that are described in Section 5.3, and the estimated cost of providing collections systems in such areas. The information is important from an economic standpoint because the cost of the collection systems in existing developed areas will necessarily be incurred if the areas are to be served.

5.4.1 Estimation of Sewer Service Type

In order to estimate the type of sewer service for areas in Hood County, a map of the region was created in ArcView using a USGS topographic map as base. Newly developed, unsewered areas were then delineated. The Certificates of Convenience and Necessity (CCN) boundaries in Hood County were overlaid to represent newly developed, unsewered areas.

These areas were then refined with a map provided by the Lake Granbury Area Chamber of Commerce that showed newly developed areas, which were assumed to be unsewered. Delineations were further refined after a field survey within the developed, unsewered areas. Figure 3-2 shows the map described.

Three types of collection systems were considered according to variation in landscape, land tract size, development spread, and proximity of each area to the groundwater table. Pressurized sewer systems were considered for hilly areas, areas near the groundwater, and areas with great development spread. Conventional gravity systems were considered for flat areas, far from the groundwater table with little development spread. Since many areas around Lake Granbury currently rely on septic systems, consideration is given to keeping areas with large land tracts far from the lake on septic systems for the time being. These areas were included in collection system analysis, and costs for collection systems were computed for them, but they are labeled “low priority” as shown in Figure 5-8. Sewer service is summarized in Table 5-7.

**Table 5-7.
Sewer Service Criteria**

System	Characteristics	Criteria	Methodology of Area Identification
Pressure	Close to groundwater table	Within 15 feet of water surface elevation	Areas outlined in ArcView
	Close to lake	Within 500 feet from lakeshore	Areas outlined in ArcView
	Hilly	Rough terrain, continuous up and down	USGS topographic maps, site visit observations
Gravity	Far from groundwater table	Greater than 15 feet from water surface elevation	Areas outlined in ArcView
	Far from lake	500 feet from lakeshore	Areas Outlined in ArcView
	Flat	Gentle terrain	USGS topographic maps, site visit observations
Septic	Large land tracts	1/2 acre and larger	Site visit observation
	Far from lake	500 feet from lakeshore	Outlined in ArcView

Fig 5-8
Foldout

Pressure and gravity sewer zones are delineated in Figure 5-8 according to the criteria in Table 5-7. The blue line defines areas with elevations within 15 feet of the water surface elevation of the lake. The orange line makes a 500-foot buffer around the lakeshore. In this analysis, the pressure zone used was the orange buffer. During construction, it is possible that sewer lines falling within the area defined by the blue line could be pressure, but this possibility would not significantly affect the cost of the project.

5.4.2 Estimation of Sewer Lengths

After delineating areas and sewer zones in ArcView, U.S. Census Bureau TIGER maps with roads and road lengths were overlaid onto the map of the Lake Granbury region in ArcView. Road lengths were then obtained for each area, totaled, and assumed to be equal to proposed pressure or gravity sewer lengths. Many areas near Lake Granbury were a composite of pressure and gravity sewer zones. In these areas, the road lengths falling into the pressure sewer service zone were summed and used to compute a percentage of pressure sewer length. The remaining road lengths composed the percentage of gravity sewer length. The total length of each type of sewer in the study area is shown in Table 5-8.

**Table 5-8.
Sewer Line Lengths**

System	Total Length (feet)
Pressure	228,222
Gravity	654,792

5.4.3 Estimation of Sewer System Cost

A preliminary cost estimate for sewerage currently unsewered areas was developed as part of the Hood County Regional Sewerage System study. The estimate is based on road lengths (measured with the ArcView GIS program), type of sewer service (gravity and pressurized), and cost data from generalized cost sources and engineering experience. The cost data is summarized in Table 5-9.

Costs were computed for each area and totals are summarized in Tables 5-10 and 5-11. A breakdown of costs for individual areas is listed in Appendix B. The assumption of one connection per 200 feet is estimated and may be overly conservative.

**Table 5-9.
Cost Data**

System	Item	Sizing and Quantity Assumptions¹	Unit Cost
Pressure	Sewer Line	Main lines will be 3-inch	\$7 per LF
	Pavement Repair	20 percent of total length	\$2 per LF
	Connections	1 per each 200 feet	\$3,000 each
Gravity	Sewer Line	Main lines will be 6-inch, manholes included in cost	\$15 per LF
	Pavement Repair	50 percent of total length	\$4 per LF
	Connections	1 per each 200 feet	\$1,500 each
Additional costs not addressed	Central lift station to pump to major interceptor or lift station		
	Land used is all in existing right-of-way		
Contingencies	Add 20 percent to costs estimated above		
	Add 15 percent for engineering/administration		
¹ Sewer lengths were assumed to be equal to road lengths in each system			

**Table 5-10.
Summary of Totals**

Total	Pressure			Gravity		
	Length	Connections	Road Repair	Length	Connections	Road Repair
Quantity (feet)	217,942	1090	43,588	653,650	3268	326,825
Cost	\$1,525,594	\$3,270,000	\$87,176	\$9,804,750	\$4,902,000	\$1,307,300

**Table 5-11.
Total Cost**

Sum of Cost	With Engineering and Administration
\$20,896,000	\$28,210,000

Section 6

Institutional and Financing Options for Ownership and Operations

There are various pros and cons associated with alternative institutional arrangements for providing wastewater service in Hood County, including a continuation of today's standalone utility circumstances and various approaches to regionalization. This issue has several higher-level considerations encompassing:

1. *Organizational approach* – stand-alone or various degrees of more regional service,
2. *Ownership* – public or private,
3. *Type of regional service* – full ownership and operations or operational management only, and
4. *Type of regional entity* – various forms of public district, municipal, or private cooperative or for-profit utilities that have varying authority to serve, access funding, and gather revenue.

These factors can be organized into general groupings for discussion as follows:

- Separate ownership and operations
 - Status quo situation
- Separate ownership and regional operations
 - Large regional district under contract
 - Municipality or smaller district under contract
 - Private operator under contract
- Regional ownership and operations
 - Regional taxing wholesale or retail district
 - Regional non-taxing wholesale or retail district
 - Municipally-owned wholesale or retail utility
 - For-profit private operator

For each of the above approaches, there are several key evaluation criteria to be considered in judging the pros and cons of each approach, including:

- Legal authority to serve,
- Asset acquisition or buyout issues,
- Presence of economies of scale affecting the cost of service,
- Breadth of service area and degree of buildout affecting service economies,

- Sources and costs of capital financing,
- Representation issues (coordination and equitable treatment of service area population),
- Willingness to serve, and
- Legal liability.

6.1 Continuation of Separate Ownership and Operations (Status Quo)

Today even though Hood County population is less than 50,000 persons, it has over 40 public and private water and wastewater utilities. The large majority of these utilities are located in a concentrated area in and around Lake Granbury and the City of Granbury. Only seven of these utilities have more than 1,000 water connections, and only four offer both water and wastewater service. The remainder utilize on-site (mainly septic) systems to accomplish wastewater disposal, but unfortunately many of these systems are old, were improperly installed or poorly maintained, and are in various stages of failure. Further, some of the centralized wastewater services in the county are overloaded. The effects of these on-site systems, in particular on the water quality of Lake Granbury (the primary source of drinking water for many in the area), is of great concern and prompted this overall study of improved regional service options.

The ad hoc and somewhat unregulated fashion in which development has historically occurred alongside the lake has resulted in the status quo situation of many, many separate utilities. This has also resulted in a relatively small degree of centralized wastewater service in the county, few economies of scale, and the inability of any single current entity being able to tackle the broader and growing regional water quality problem.

As shown in Table 6-1, which provides information concerning ownership and operations options, the status quo situation of separate utility ownership and operations already has or can gain the legal authority to serve at the State level through district creation or granting of a utility certification. If the individual utilities can meet any new county sewer requirements, that should not be an impediment to legal authority to serve either. But the proliferation of even more separately-owned and managed utilities will further increase coordination problems, result in more questionable ability to run quality utility operations over time, likely be less willing to serve intervening areas, lose economies of scale, and incur higher costs of capital financing.

Table 6-1.
Comparison of Alternative of Institutional Approaches to Wastewater Utility Service

Ownership	Possible Entity(ies) Involved	Legal Authority	Acquisition Issues	Economies of Scale	Source & Cost of Financing	Size of Service Area and Degree of Build Out	Equity & Coordination Issues	Willingness to Serve	Wastewater Discharge Permit Liability
Separate Ownership & Operations	Current mix of municipal, special water district and private corporations	Existing utilities are empowered under provisions of the Texas Local Government Code and Water Code; New districts or private utilities may require state creation or service area certification	No acquisition issues except as may exist by municipalities or districts potentially needing to acquire existing systems in any annexed areas.	Small, except as may exist with broader City or MUD service areas.	Municipalities - capital likely financed with revenue bonds placed with TWDB SRF. Districts - likely combination tax/revenue bonds placed with TWDB SRF. Water corporations - private financing. State SRF financing likely cheapest available.	The somewhat non-contiguous historical growth pattern has fostered the creation of separate utilities. The lesser economics of low-density buildout has been borne to date by these separate utilities. However over time, a greater degree of buildout and infill has occurred.	Too many utilities for well coordinated action. Although with separate utilities, utility management provides representation closer to the customer base and may be more or less responsive in terms of their ability to deal with problems. Quality of service may vary as well.	Barriers to expanding service exist given discrete service areas, ability to fund capital expansion, and local political issues.	Remains with owner.
Separate Ownership & Regional Operations	Larger regional district or authority under contract	If new, may require creation by State Legislature or TNRCC administrative action. BRA already has such authority.	Same as above	Operational and administrative savings possible.	Same as above for capital; O&M financed by rate revenue.	May be better focused on serving the non-contiguous service area and have broader base of customers & activities to weather economic fluctuations.	Contract manager can be terminated if unresponsive to needs of customers. Likely separate contracts and rates could be maintained.	Barriers to expanding service exist given discrete service areas, ability to fund capital expansion, and local political issues.	While penalties may be assigned to the operator through contract provisions, ultimate liability still remains with the owner.
	Municipality or smaller district under contract	If no city charter or district creation problems, could be accomplished through contract agreements among participating parties.	Same as above	Operational and administrative savings possible.	Same as above for capital; O&M financed by rate revenue.	There may be more questions of service priorities than with a regional manager. May have lesser ability to shift funds to weather economic fluctuations.	Contract manager can be terminated if unresponsive to needs of customers. Likely separate contracts and rates could be maintained.	Barriers to expanding service exist given discrete service areas, ability to fund capital expansion, and local political issues.	While penalties may be assigned to the operator through contract provisions, ultimate liability still remains with the owner.
	Private operator	Could be accomplished through contract agreements among participating parties.	Same as above	Greater operational and administrative savings possible, but savings may be offset to some degree by presence of profit and taxes in the rates.	Same as above for capital; O&M financed by rate revenue.	May be better focused on serving the non-contiguous service area. May be less able to weather economic fluctuations.	Contract manager can be terminated if unresponsive to needs of customers. Likely separate contracts and rates could be maintained.	Barriers to expanding service exist given discrete service areas, ability to fund capital expansion, and local political issues.	While penalties may assigned operator through contract provisions, ultimate liability still remains with the owner.
Regional Ownership & Operations*	Regional taxing district	Would require creation by State Legislature or TNRCC administrative action.	One possibility is that regional district or authority owns only new capital. Second possibility is that district or authority issues bonds and buys out some portion or all of the existing systems.	Operational and administrative savings possible.	District capital likely financed with combination tax/revenue bonds placed with TWDB SRF. Possibly cheaper than current situation. O&M could be financed by rate and tax revenue.	A taxing district could benefit from some financial support from undeveloped properties, although district boundaries would have to be carefully drawn around properties for which service is ultimately intended.	May better represent the broader interests of the region. Areas with current systems may want some differential rates to account for capital they've already paid for.	Less barriers to extending service within larger district boundaries, broader representation, and collection of area-based tax revenues.	Remains with owner
	Regional non-taxing district or authority	If new, may require creation by State Legislature or TNRCC administrative action. BRA already has such authority.	Same as above	Same as above	If BRA, good credit rating and bundling of financing with other BRA projects may produce economies in financing.	A revenue-based district provider would realize higher unit service costs from low densities, but no offsetting return from undeveloped properties as would a taxing district.	May better represent the broader interests of the region. Areas with current systems may want some differential rates to account for capital they've already paid for.	Less barriers to extending service if contract terms are agreeable, but rate-based revenue may somewhat deter capital expansion into new areas.	Remains with owner
	Regional municipal provider	If no city charter or district creation problems, could be accomplished through contract agreements among participating parties.	One possibility is city owns only new capital. Second possibility is that city issues bonds and buys out some portion or all of the existing systems.	Same as above	Municipal capital likely financed with contract revenue bonds placed with TWDB SRF. O&M would be financed by rate revenue.	Same as above	Concern may exist about preferential in-city versus out-of-city service. Areas with current systems may want some differential rates to account for capital they've already paid for.	Less barriers to extending service if contract terms are agreeable, but rate-based revenue may somewhat deter capital expansion into new areas.	Remains with owner.
	Private entity	Would require utility service area certification by the state and contract agreements among participating parties.	One possibility is private operator owns only new capital. Second possibility is that private operator finances buy out of some portion or all of the existing systems.	Greater operational and administrative savings possible, but savings may be offset to some degree by presence of profit and taxes in the rates.	Capital financed through private markets or internally at potentially higher costs than government financing. O&M would be financed through rate revenue.	Same as above	May better represent the broader interests of the region, but does have profit motive at basis of service. May entail some loss of promoting other governmental policies (e.g. growth and development patterns, etc.)	Less barriers to extending service if contract terms are agreeable, but rate-based revenue and private source of funds may somewhat deter capital expansion into new areas.	Remains with owner

* Each of these options would have pro/con issues related to the provision of wholesale, retail, or combined wholesale/retail service discussed in the text.

The status quo is not likely to continue for at least two reasons. First, new legal authority has been given to Hood County government to condition rural development for the provision of improved (or less impacting) wastewater service. However, requiring improved treatment systems for larger developments could exacerbate the already undesirable trend of even more small utilities with their questionable ability to maintain quality utility service over time. Furthermore, the new county authority leaves the large degree of existing development in the county and current water quality problems mostly unaffected. The second initiative to examine and innovate regional solutions to wastewater service could, if implemented, potentially address the existing development situation and provide an avenue for integration of new developments into a regional system over time. But how does the existing situation foster or deter the feasibility of a regional wastewater system?

While relatively few of these utilities offer wastewater service, the presence of these many disparate water utilities complicate the implementation of a regional wastewater system in that there are:

- A large array of entities to deal with,
- A broad expanse of potential regional service to span the many utilities,
- Defined monopoly service areas (Certificates of Convenience and Necessity) that may impede regional service arrangements,
- Possible buyout/asset acquisition issues, and
- Water and wastewater service tends to go hand-in-hand (for billing and other purposes).

On the other hand, this situation also provides:

- Organized entities with which to communicate and negotiate,
- Existing customer bases on which to draw,
- Possibilities for cooperating, but separate, water and wastewater service,
- Economies in sharing easements or other operational functions,

6.2 Alternative Regional Arrangements

6.2.1 Separate Ownership and Regional Operations

With this broad alternative, utility systems in the county would be owned by separate entities, but management of operations and maintenance for some or all of these systems would be performed under contract by a regional management authority of some form.

There are some aspects that are common to all three forms of contract management discussed below:

- In terms of quality of service, any of the three forms of contract management discussed here are subject to performance reviews and possible termination if the service is not up to acceptable levels. Prior performance of any existing entities should be reviewed.
- Since the capital assets would remain with the original owners, the current costs of financing capital improvements would remain the same as today.
- With the contract management approach, barriers to expanding service areas may continue as these decisions would still remain in the hands of the multitude of individual “utility boards” who would be faced with capital financing, political, or other issues involved in expanding service.
- While penalties to the contract manager may be provided for in the contract terms, hiring a contract manager does not fully absolve the separate owner of the utility from legal liabilities associated with the wastewater discharge permit or other operational issues. The owner has primary responsibility.
- It is likely that any outside operating entity (with other responsibilities) may want some type of “mark-up” for services rendered which may act to somewhat offset economies gained in regional operations.

6.2.1.1 Larger Regional District or Authority under Contract

If a new regional entity were to provide contract management service, it would have to be created by legislative or TNRCC administrative action and be subject to a confirmation election of the board. However, the BRA already has that authority and is currently providing regional wastewater service and contract management service to a number of entities.

Because the regional entity would be providing only management services, there would not likely be any asset acquisition issues.

In terms of costs, there would likely be economies of scale savings in conducting regional operations. Bulk purchases of supplies, reduction of redundant personnel, possible automation of operations, etc. are all potential sources of efficiency savings.

With a broader base of customers, a regional management entity would not likely be as vulnerable to economic fluctuations as would a smaller utility and is likely to have the resources to expand its operating services more easily.

6.2.1.2 Municipality or Smaller Water District under Contract

There is currently no perceived need to gain new legal authority for this purpose. Currently, both the City of Granbury or Acton MUD have the legal authority to contract for and provide utility operating services outside of their municipal or district boundaries. For legal and/or political reasons, both entities would need to cost-insulate their current constituents from any additional expense associated with providing regional management services.

A smaller entity providing such management services may have less financial depth and flexibility in weathering economic fluctuations. Questions could also arise from customers about service priorities and fair representation, although contract performance could be reviewed periodically.

6.2.1.3 Private Operator under Contract

Since the legal authority to provide utility service would still reside with the separate owner, a private operating company would only need a service contract and properly certified personnel on staff to operate a wastewater system.

Even greater service economies might be obtained with a private operator through less expensive purchasing procedures than are available to governmental entities. However in hiring a private operator, two additional expenses are incurred (taxes and profit) that would not be explicitly incurred with a government entity providing the service. *[It should be noted that the "bottom" line consideration on potential savings versus additional costs is the offering price at which any public or private operating entity will agree to for quality service over a sufficient period of time.]*

6.2.2 Regional Ownership and Operations

With this broad alternative, utility systems in the county would be owned (in whole or in part) and operated by a regional utility.

There are some aspects that are common to all four forms of regional owner/operator utilities discussed below:

- Each approach has potential wholesale-only, mixed wholesale-retail, or full retail service configurations that could be structured.
- The *wholesale-only* regional option leaves the provision, operation, and maintenance of internal (subdivision-type) infrastructure in the hands of a smaller retail utility.

This will likely create unique retail rate structures for each utility, may or may not require the acquisition of existing major wastewater treatment or large collection infrastructure, and may continue current problems of the ability of neighborhoods to finance and adequately maintain local collection infrastructure.

- The *mixed wholesale-retail* regional options could be tailored to specific situations. While existing sewer utilities (with collection systems already in place) may only want to purchase wholesale treatment service, it is probable that developments without centralized service would benefit most from the provision of full service by a regional entity.
- The *full retail* regional service option may be possible if existing centralized systems are willing to transfer their systems to the regional entity. This may involve acquisition of assets or possibly different retail rate structures (where existing systems get some credit for infrastructure already paid for). The greatest economies of scale are likely to be obtained with this approach consolidating all capital, operations, maintenance, and administrative activities.
- Each regional ownership option may lessen, to some extent, the consideration of providing utility service as a tool for helping promote other non-utility public policy or land use goals of government or neighborhoods. If wholesale service were provided, that would leave some growth and land use considerations in the hands of the retail utility who may then decide on whether to extend retail service. However, it may also be possible for the wholesale utility to sell direct to a new retail utility and thus circumvent any growth or land use considerations of neighboring entities.
- All three of the above approaches could adopt impact fee or service extension policies that would, for instance, require a developer (or builder) to pay a fee towards capital funding of the utility and/or for the facilities needed to extend service to their property. Some entities have also negotiated for a developer to initially pay for some oversizing of the approach lines with the developer being repaid for that oversizing through the payment fees from “subsequent users” of that facility. A range of possible impact fee revenues are shown in Table 6-2. These funds may take some time to accrue to useful levels for project spending and are usually best applied as a cash contribution towards construction rather than being used to pay debt service.

6.2.2.1 Regional Taxing District

A regional sewer district with taxing authority would have to be created by Legislative or TNRCC administrative action. Also, the board members and tax bond authorization limit would have to be confirmed by district voters. If successful, this type of regional entity would have an elected board that would provide direct representation of the local customer base.

There may be several funding advantages involved in a regional taxing district. Such a district would have the ability to jointly pledge utility tax and rate revenues to get low lending rates. District property owners would be able to “write-off” the local tax on their Federal taxes

Table 6-2.
Amount of Cash-Funded Capital Project Support
with Alternative Impact Fees and New Connections

Alternative Fee Amount	Number of New Connections				
	1,000	5,000	10,000	15,000	20,000
\$500	\$500,000	\$2,500,000	\$5,000,000	\$7,500,000	\$10,000,000
\$1,000	\$1,000,000	\$5,000,000	\$10,000,000	\$15,000,000	\$20,000,000
\$1,500	\$1,500,000	\$7,500,000	\$15,000,000	\$22,500,000	\$30,000,000
\$2,000	\$2,000,000	\$10,000,000	\$20,000,000	\$30,000,000	\$40,000,000
\$2,500	\$2,500,000	\$12,500,000	\$25,000,000	\$37,500,000	\$50,000,000
\$3,000	\$3,000,000	\$15,000,000	\$30,000,000	\$45,000,000	\$60,000,000

for those itemizing their returns (saving about 20 percent on average). The district could also benefit from having undeveloped property (that benefits or appreciates from the presence of the regional sewer system) help pay for the cost of carrying oversized and having service available.

Table 6-3 indicates the various amounts of debt-funded capital project support with alternative levels of taxation and tax base within a special district or the county.

Table 6-3.
Amount of Debt-Funded Capital that could be
Supported with Alternative Tax Rates and Tax Bases¹

Alternative Tax Rate/\$100 a.v.	Tax Base (bill.\$)				
	\$0.500	\$1.000	\$1.500	\$2.000	\$2.500
\$0.01	\$550,000	\$1,100,000	\$1,650,000	\$2,200,000	\$2,750,000
\$0.02	\$1,100,000	\$2,200,000	\$3,300,000	\$4,400,000	\$5,500,000
\$0.03	\$1,650,000	\$3,300,000	\$4,950,000	\$6,600,000	\$8,250,000
\$0.04	\$2,200,000	\$4,400,000	\$6,600,000	\$8,800,000	\$1,100,000
\$0.05	\$2,750,000	\$5,500,000	\$8,250,000	\$11,000,000	\$13,750,000
\$0.06	\$3,300,000	\$6,600,000	\$9,900,000	\$13,200,000	\$16,500,000
\$0.07	\$3,850,000	\$7,700,000	\$11,500,000	\$15,400,000	\$19,250,000
\$0.08	\$4,400,000	\$8,800,000	\$13,200,000	\$17,600,000	\$2,200,000
\$0.09	\$4,950,000	\$9,900,000	\$14,850,000	\$19,800,000	\$24,750,000
\$0.10	\$5,500,000	\$11,000,000	\$16,500,000	\$2,200,000	\$27,500,000

This could be a factor in supporting the capital cost of the system given the amount of undeveloped property lying between existing subdivisions and remaining undeveloped lots in existing subdivisions.

However, the apparent public “stigma” against new taxes may pose difficulties in creating such a district. Also, drawing potential district boundaries to include the maximum number of those in need, and at the same time, fostering a successful bond authorization election with possible opposition from functioning septic tank owners and undeveloped land owners in the district may prove challenging. Further, the taxing district will also be faced with implementing a viable and timely plan to extend service to those in the district, given the somewhat higher responsibility to ultimately serve those paying taxes.

6.2.2.2 Regional Non-taxing District or Authority

If a new regional entity were to provide contract management service, it would have to be created by legislative or TNRCC administrative action and be subject to a confirmation election of the board. A new local district could provide direct elected representation for local entities. However, the BRA already has the needed authority and is currently providing regional wastewater service to a number of entities in other portions of the basin. While the amount of direct representation of local entities may lessen with a BRA regional system, the Authority has been very diligent in forming and responding to local advisory groups in the areas where it is providing regional service.

This type of non-taxing regional entity would likely rely on revenue bond funding that would be secured through either wholesale service contracts and/or a pledge of retail revenues of the regional system. This source of funds may cost slightly more than a district, which could also pledge tax revenues to secure bond repayment. The BRA already has a track record of utility service and access to low-cost funds that a new district may not enjoy.

The funding of oversizing to serve intervening undeveloped property could be accomplished several ways with a non-taxing district or authority. One approach would be to fund the oversizing with many of the other major district facilities in the initial bond issue(s) and have the initial ratepayers start paying for it immediately. Two other approaches would involve “backloading” the payment of the bond issue(s) or to obtain interim funding support from the State Participation Program. In either of these instances, higher debt service would result in the

latter years of the bond term and would be paid at that time by all rate payers (old and new customers alike).

6.2.2.3 Municipality Regional Provider

This option would be similar to the non-taxing district above with a city also using revenue or contract revenue bonds to provide for capital facilities for the out-of-city service, recovering full O&M expenses, and possibly some rate of return for the out-of-city service. While there might be some concerns about which customers get priorities, the municipality could also provide for a regional advisory council for input to service considerations. A city could also implement impact fee or service extension policies similar to those discussed above.

6.2.2.4 Private Entity

This type of regional utility would likely be subject to higher costs of capital financing through private external or internal funding sources. However, there may be greater O&M efficiencies possible with a private utility through streamlined purchasing and other cost saving approaches. Offsetting to some degree those savings would be additional expenses in the rate base of taxes and profit. A private investor-owned utility may also place greater weight on purely business decisions facing utility service or expansion matters and may give less weight to other public policy issues. Direct representation by customers in utility decisions may be less with this type of utility, but customers of investor-owned utilities are typically allowed meaningful input to rate proposals that must receive TNRCC review and approval.

6.3 Institutional Conclusions

Each approach to institutional organization discussed above has both its pros and cons. Probably the least effective approach is a continuation of the status quo mix of many public and private utilities attempting to address (or not address) the current and future wastewater issues.

Regionalizing just the operations and management of wastewater treatment and disposal in Hood County could gain some economies and be *a logical first step* towards a broader regionalization program. However, regional management, in and of itself, does not address the issue of feasibly expanding centralized wastewater service into significant new areas, nor does it gain the more significant economies of scale, cost savings, and improved operations that are typically associated with the provision of regional collection and treatment facilities.

Public utilities generally have access to lower cost financing and may provide a greater degree of representation of the public interest, but may also be constrained by more restrictive laws and policies than is the private sector.

The broadest base of financial support, possibly lowest cost of funding, and direct representation of customers would probably come through the implementation of a regional district with elected board members and taxing authority, but this would involve the challenge of promoting a successful tax bond authorization election. A non-taxing regional authority, such as BRA, could also provide relatively low-cost financing and good representation as well or serve as a wholesale treatment provider to a new regional district that could provide the retail functions. However, BRA typically issues contract revenue bonds which use pledge the credit of the contract participants to repay the bonds. This implies that there needs to be some governmental entity, such as a special water district, that can contractually cover the residents in the county outside of Granbury and Acton. As indicated in Table 6-4, the Hood County government is limited in this regard as it cannot issue general obligation (tax) bonds for water and wastewater capital funding.

The retailing function would entail many political and financial decisions about where and when to extend service in the county, programs for gaining hook-ups, cost-sharing and rate-making decisions, collecting impact fees, etc.. These issues may be better represented locally by an elected board of special water district. The cost of funds for a *start-up* taxing district or the revenue bonding ability of the BRA would probably be somewhat comparable and not make a significant difference in the foreseeable cost of service of a regional utility.

If regional ownership of facilities were pursued, a combination of wholesale service (to existing wastewater utilities in the immediate Granbury and suburban areas) and retail service (to newly expanded wastewater service areas) might be a more feasible initial approach. Then, over time, consideration could be given to pursuing full regional retail service to the entire area.

6.4 Alternative Sources of Financing

As discussed above, various sources of financing and funding tools (taxes, rates, fees, etc.) may be associated with certain types of institutional organization. For instance, private utilities are restricted from certain financing and funding tool options that are generally available to public entities.

Table 6-4.
Funding and Regulatory Capabilities of Potential Regional Entities with
Specific Legal Authority Hood County Regional Wastewater Plan

Legal Authority to:	BRA	Hood County	Special Water District*
Own and operate a water and wastewater utility	1929 Legislative Act	Somewhat unclear authority. Section 412.016 appears to grant authority broadly to all counties, but makes prior Section 412.015 redundant that provides authority only for affected counties that qualify as Economically Distressed Areas under Section 16.341 of the Water Code.	Can be empowered Legislatively with specific authority for purposes mentioned below.
Levy utility rates	Yes	Yes	Yes
Levy and valorem taxes	No	Yes, county-wide, but unable to use for payment of general obligation bonds under Section 412.016 of Local Government Code.	Yes, district-wide, able to levy an valorem taxes for both debt and maintenance purposes, subject to review of TNRCC.
Levy impact fees	Unclear authority in Chapter 395 of Local Government Code. Statute addresses political subdivisions, but written with focus on municipalities and water districts in key sections.	Unclear authority in Chapter 395 of Local Government Code. Statute addresses political subdivisions, but written with focus on municipalities and water districts in key sections.	Yes, under TNRCC review authority.
Levy stand-by fees	No explicit authority	No explicit authority	Yes, under TNRCC review authority.
Enact dedication ordinances or policies	Could establish policy as condition of extending service, but no ordinance ability.	Could establish policy as condition of extending service, but no ordinance ability.	Yes
Enact other regulatory authority	No	SB709 authority to regulate location, design, extension, size, and installation of water and wastewater utility in unincorporated areas of the county, including requiring connection to centralized system. Can also customize regulation by specially-defined districts within the county.	If included in creation authority.
Issue Bonds	Revenue bond authority only. BRA has demonstrated credit history and financial capability.	Revenue bond authority only under Section 412.016 of Local Government Code. Ad valorem revenues cannot be used to pay G.O. Bond debt. County has demonstrated credit history and financial capability.	Typical authority for tax and/or revenue bonds. Must establish credit history and financial capability.
* With authority created under Article XVI, Section 59 or Article III, Section 52 of the Texas Constitution.			

For public entities, there are at least three major sources of financing for wastewater projects, including:

1. Open market bonds;
2. Various programs through the Texas Water Development Board, and
3. Grants from Federal agencies.

6.4.1 Open Market Bonds

Public agencies borrow funds in the financial markets through the issuance of bonds, then use the proceeds to construct public water supply and wastewater projects such as water supply reservoirs, water wells, pipelines, water treatment plants, sewage treatment plants, pump stations, storage tanks, and associated capital equipment. The bond holders would be repaid with interest from revenues and/or fees collected from those who receive water and sewer services. In cases where public entities issue bonds to supply water and/or wastewater services to the public, the bonds are classified under federal laws as “tax exempt.” On tax exempt bonds, the interest paid to the bondholders is not considered as ordinary income; therefore, the bondholder does not have to pay income tax on the earnings from these investments. As a result, individuals and other investors are willing to lend their capital to governmental entities at lower interest rates than would be the case if the interest on those loans (bonds) were taxed by the federal government.

6.4.2 Texas Water Development Board Programs

The TWDB has an array of financial assistance programs, but only three are generally applicable to the financing of a regional wastewater system. Two of these programs in particular, the Clean Water State Revolving Fund and the State Participation Program, might provide advantages to Hood County in capital financing of the reclaimed water program and should be examined for competitiveness with existing government internal or open-market financing options.

6.4.2.1 Clean Water State Revolving Fund (CW-SRF)

The CW-SRF was established in 1987 to provide a financing source for wastewater treatment and non-point source pollution control projects. The SRF provides below market interest loans to eligible political subdivisions for construction, improvement, or expansion of sewage collection and treatment facilities. The SRF is funded through a combination of federal

clean water grants and state water quality enhancement bond funds. In order to be eligible for SRF financing, an applicant must be a political entity with the authority to own and operate a sewage system.

6.4.2.2 State Participation Fund

The concept of State Participation, as it applies to water supply and water quality protection projects, is as follows. A local area needs an additional water source, transmission pipelines, storage reservoir, and treatment plant, or has wastewater collection and treatment plant needs. The area's existing customer base can only support monthly rates required to repay loans for a project sized to meet present needs. However, if a project is built to only meet present needs, it may soon be inadequate. Thus, through the State Participation Fund, the local entity could plan a larger project, with phased construction of the separate elements to the extent possible, and apply to the TWDB for state participation in the project. Under this arrangement, the TWDB would become a "silent partner" in the project by entering into an agreement with the local entity to pay up to half of the project costs initially. The TWDB would hold the remaining project share until a future date, at which time the local entity would be required to buy the TWDB's share.

The terms and conditions of such an agreement are negotiated for each case. Typically, the local entities are required to pay simple interest on the TWDB's share of the project cost from the beginning and to begin buying the TWDB's share, including accumulated interest, at a specified future date, usually within 8 to 12 years of project completion. By lending the state's credit to local areas, an optimal longer-term development plan for growing areas can usually be implemented at lower costs. However, the recipient of the loan will be required to repay the TWDB, including interest and financing costs incurred.

It should be emphasized, however, that the state participation fund is appropriate and reasonable only for additional project capacities (oversizing). Also, the relative attractiveness of the State Participation Program increases if: (1) the oversizing is typically carried by the State for a longer period of time (10 or more years), and/or (2) there is a higher degree of uncertainty if major customers will utilize this excess capacity in the near- to medium-term.

6.4.2.3 Texas Water Development Fund (D-Fund)

The TWDB has authority granted by Texas Constitutional Amendments and state statutes to issue State of Texas General Obligation Bonds to provide loans to political subdivisions and special purpose districts for the construction of water supply, sewer, and flood control projects under the auspices of the Texas Water Development Fund.

The TWDB uses the proceeds of its bond sales to purchase the bonds (either general obligation or revenue) of cities and local water districts and authorities, which in turn use the borrowed funds to pay for construction of local projects. The local district or city repays the TWDB, with interest equal to the rate that the TWDB must pay on its bonds plus 0.5 percent, which the TWDB uses to retire the bonds it issued. The 0.5 percent assists the state in repaying the cost of administering the loan program. However, the interest rate on TWDB bonds is specific to each TWDB bond sale and therefore varies as market conditions change.

The State of Texas water resources loan program enables some cities and local districts, especially smaller entities that do not have a credit rating or sufficient credit rating to utilize the credit of the State in financing projects and thereby obtain financing at lower interest rates than if they were to sell their bonds on the open bond market. While this financing program is available, Hood County should evaluate if its open market bonds options can provide lower rates than could be obtained through this program of the State.

6.4.3 Federal Grants

For the most part, federal financing assistance for wastewater is made through the federal grant contribution to the state revolving loan programs, which provides for the below-market interest rates on the program's loans. It is possible that other sources of federal grant funds, such as Community Development Block Grants, may be available to address the wastewater infrastructure need (particularly the internal collection systems) if certain eligibility criteria are met and the allocated funds are not designated for other community priorities.

Section 7 Implementation Plan

7.1 General

Key factors in implementation of a regional wastewater system involve selection and implementation of an organization for the administration, operation and management of the system, arrangement of financing, and design (including permitting and environmental work) and construction of facilities. Figure 7-1 provides a simplified schematic indicating the key steps associated with implementation of a regional wastewater system. Information regarding implementation is provided in subsequent paragraphs of this section.

7.2 Organization

Possible organizational structures defining ownership and operational responsibilities have been described in Section 6. There are a variety of ownership and operational options available for a regional system. Study area entities need to evaluate the options described in Section 6 on an individual basis and on a collective basis to determine the ownership and operational structure that best meets the wastewater needs of the area.

Establishing an ownership and operational structure involves legal, financial, technical and other issues. Legal counsel and financial advisers should be consulted and their input considered by regional system participants in developing an organizational structure. Decisions regarding structure of a regional organization need to be made concurrently with decisions regarding financing, as some financing options are dependent on organizational structure.

7.3 Funding and Financing

Sources of funding and financing for the project have been described in Section 6. Funding the regional system in the years immediately following implementation is a recognized issue that must be addressed. Future needs dictate that collection system components be sized to handle projected future needs, while components of treatment and pumping facilities can generally be staged to meet short-term needs (except for land and some facility infrastructure components). Sizing components to meet future needs results in expenditures to serve users that are not yet in place, and, unless financing techniques are used to defer debt service (such as the

(This page is intentionally left blank.)

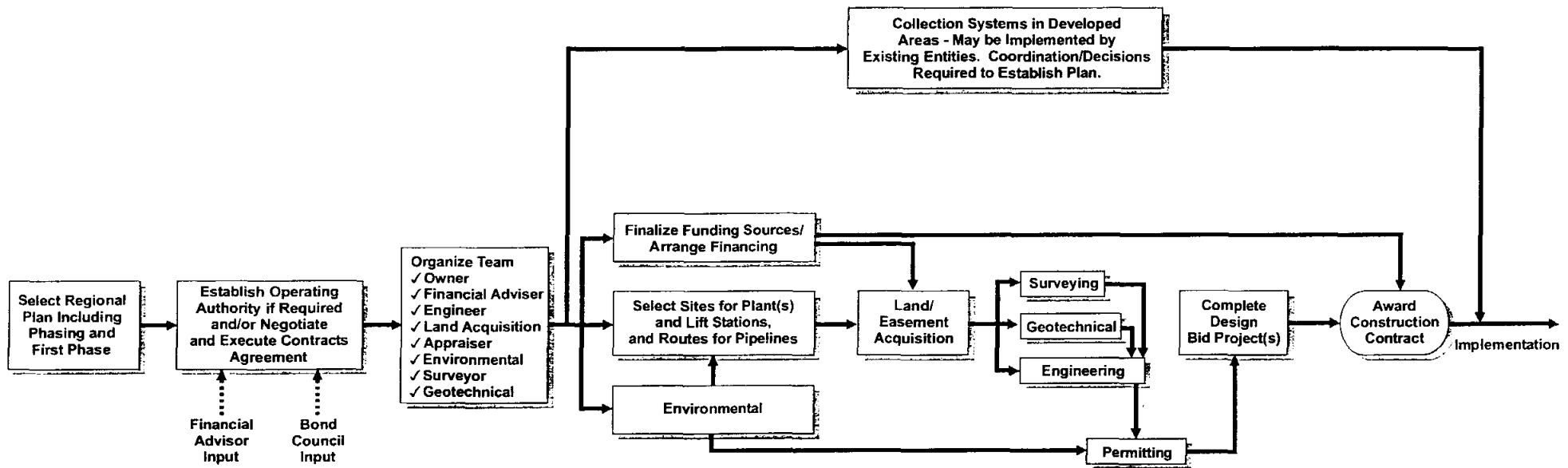

Notes:

1. Multiple construction projects are anticipated for Lines and Lift Stations.
2. Geotechnical work and surveying may be initiated prior to completion of acquisition depending on nature of negotiations.
3. Arrangements can normally be made to conduct surveying and geotechnical work while land acquisition negotiations are in progress.

Figure 7-1. Simplified Schematic Implementation Plan for Regional Wastewater System

Texas Water Development Board State Participation program described in Section 6, or a "back-loaded" debt service schedule that increases over time), results in a heavy burden on existing customers.

Ultimately, the cost of wastewater service should be borne by users through the wastewater rate system. Initially, though, when the customer base is small, the regional participants may choose to cover a portion of the cost of the wastewater system through taxes, and taxes may be appropriate as a funding source on a long term basis if there is undeveloped property that will benefit (appreciate) due to the availability of service from a regional system. It is possible that participants could use taxes to cover some portion of their costs even if the regional operator or owner did not have taxing authority to fund the system. Given the high costs of the potential system, serious consideration should also be given to use of additional funding "tools", such as the levy of impact fees charged to new growth and/or required infrastructure dedications from developers for extensions or additional facilities required to serve their development.

Financing and funding a regional system is a complex and obviously important issue. Estimated costs have been identified for a regional system. As indicated in Section 7.2, Organization, financial advisers and bond counsel should be consulted and their input included as part of the decision making process on financing and funding.

7.4 Regional Wastewater Collection and Treatment Facilities

Recommended regional wastewater facilities are those described as Alternative 6 in Section 5. Key components of Alternative 6 and a staging plan for implementation have been shown in Figure 5-6, and key components are listed below. It should be emphasized that all plant locations are approximate. Detailed siting studies and information developed during preliminary design could result in considerable changes in plant location.

1. Major wastewater treatment facilities in Hood County will include the existing City of Granbury, City of Lipan, and City of Tolar plants plus a new plant west of Granbury (between FM 4 and the US 377) and a new plant in the southern part of the County near SH 144 and Mitchell Bend Highway (adjacent to the proposed power plant).
2. The existing Acton MUD plants will stay on-line until economics allow them to be taken out of service. Due to location and site constraints, the plants are not included as part of the long-term wastewater system for the County.

3. Adequate land will be acquired at the proposed wastewater treatment plant and lift station sites to accommodate advanced treatment plants (similar to existing Granbury plant plus filters or membranes to further improve quality of water produced) for plants sized to treat the projected year 2030 high growth flow (County population of 120,000, and treatment capacity provided to treat a peak month flow of 16.7 MGD).
4. Due to costs and attendant staging that will be involved in implementation of a regional system, package plants will almost certainly be used to meet wastewater treatment needs, particularly for new development. TNRCC permitting will be required for package (or any treatment plants), and entities in Hood County should participate in hearings for any new treatment facilities and request that any such permits include a Special Provision requiring that treatment facilities be phased out and collection systems be connected to a regional system when a regional system becomes available. Any project funding through Texas Water Development Board (TWDB) administered program will require approval of the population projections used to size facilities, or oversizing above capacity required to handle TWDB approved population projections will have to be funded locally.
5. Initial treatment plant and lift station capacity will be sized to handle the projected year 2020 Senate Bill 1 population and attendant projected year 2020 wastewater flow (County population of 67,659, and treatment capacity provided to treat a peak month flow of 9.4 MGD).
6. Interceptor and collection system lines will be sized to handle projected instantaneous peak flows expected to accompany the year 2030 high growth population of 120,000. The conveyance facilities will be sized for the high growth projections because of the economy of scale associated with pipeline construction and because of the costs that would be associated with increasing conveyance facility capacity in the future.
7. The total estimated cost associated with implementation of Alternate 6 is \$129,368,000.

Appendix A
Alternative 6 Costs

**Hood County Wastewater Study
HDR No. 00044-067-036**

Breakdown of Capital Costs for Alt. 6
12/18/00

		Construction Costs	Easement/Land Costs	Total Capital Costs
Sewer Lines	A1-A2	\$692,391	\$2,864	\$695,000
	A3-A4	61,020	4,881	66,000
	A4-A2	398,685	11,391	410,000
	A2-'A'	1,322,220	13,222	1,335,000
	B1-B2	194,685	1,947	197,000
	B2-B3	548,455	4,566	553,000
	B3-B4	157,230	3,931	161,000
	B4-B5	439,750	16,086	456,000
	B5-B6	291,822	9,924	302,000
	B6-C3	756,887	7,050	764,000
	C1-C2	72,160	4,711	77,000
	C2-C3	571,310	13,267	585,000
	C3-D2	421,186	7,002	428,000
	C4-C5	246,798	2,656	249,000
	C5-C6	1,158,568	8,282	1,167,000
	C6-D6	917,018	18,341	935,000
	D1-D2	979,993	6,594	987,000
	D2-D3	549,224	937	550,000
	D3-D7	1,334,070	6,670	1,341,000
	D4-D7	184,950	9,247	194,000
	D7-'D'	1,698,750	2,831	1,702,000
	D6-D5	1,028,228	2,285	1,031,000
	D5-'D'	1,780,494	3,564	1,784,000
Lift Stations	A1	458,000	14,000	472,000
	A2	1,472,000	14,000	1,486,000
	A3	114,000	14,000	128,000
	A4	147,000	14,000	161,000
	B1	105,000	14,000	119,000
	B2	442,000	14,000	456,000
	B3	360,000	14,000	374,000
	B4	654,000	14,000	668,000
	B5	360,000	14,000	374,000
	B6	491,000	14,000	505,000

**Hood County Wastewater Study
HDR No. 00044-067-036**

Breakdown of Capital Costs for Alt. 6
12/18/00

		Construction Costs	Easement/Land Costs	Total Capital Costs
	C1	114,000	14,000	128,000
	C2	262,000	14,000	276,000
	C3	752,000	14,000	766,000
	C4	360,000	14,000	374,000
	C5	1,308,000	14,000	1,322,000
	C6	1,668,000	14,000	1,682,000
	D1	1,439,000	14,000	1,453,000
	D2	2,649,000	14,000	2,663,000
	D3	2,649,000	14,000	2,663,000
	D4	294,000	14,000	308,000
	D5	2,322,000	14,000	2,336,000
	D6	2,878,000	14,000	2,892,000
	D7	1,472,000	14,000	1,486,000
	Closest Lift Station			
Collection Systems	A1	1,561,829		1,561,829
	A2	2,865,418		2,865,418
	A3	366,655		366,655
	A4	84,188		84,188
	B1	855,066		855,066
	B2	958,150		958,150
	B3	363,417		363,417
	B4	1,141,164		1,141,164
	B5	1,290,866		1,290,866
	B6	1,050,583		1,050,583
	C1	605,486		605,486
	C2	1,154,152		1,154,152
	C4	301,447		301,447
	C5	1,138,586		1,138,586
	C6	946,388		946,388
	D2	2,388,923		2,388,923
	D3	781,776		781,776
	D4	1,775,585		1,775,585
	D5	1,266,653		1,266,653
Treatment Plants	A	3,760,000	288,000	4,048,000
	D	10,053,000	509,000	10,562,000
	D exp.	12,257,000		12,257,000

**Hood County Wastewater Study
HDR No. 00044-067-036**

Breakdown of Capital Costs for Alt. 6
12/18/00

	Construction Costs	Easement/Land Costs	Total Capital Costs
Subtotals	\$85,542,000	\$1,281,000	\$86,824,000
Contigencies (20%)			\$17,364,800
Engineering (13%)			\$11,287,120
Surveying (5%)			\$4,341,200
Testing (5%)			\$4,341,200
Administration (2%)			\$1,736,480
Resident Project Rep. (4%)			\$3,472,960
Grand Total			\$129,368,000

Appendix B
Cost Breakdown to Provide Sewerage
Service for Existing Developed Areas

Cost Breakdown to Provide Sewerage Service for Existing Developed Areas							
Area		Gravity	Pressure		Cont.	Engr.	Grand
ID	Developments	Costs	Costs	Subtotal	20%	15%	Total
2	Mid Haven Estate	\$104,193	\$0	\$104,193	\$20,839	\$15,629	\$140,661
3	Brazos River Acres	529,124	61,154	590,278	118,056	88,542	796,875
4	River County Acres	334,052	78,930	412,983	82,597	61,947	557,527
5	Hunterwood	159,199	0	159,199	31,840	23,880	214,919
6	Canyon Creek	1,095,238	543,592	1,638,831	327,766	245,825	2,212,421
8	Hills of Granbury	248,399	0	248,399	49,680	37,260	335,339
9	Comanche Harbor	998,715	181,781	1,180,496	236,099	177,074	1,593,669
10	Rock Harbor	138,527	238,172	376,699	75,340	56,505	508,543
11	Comanche Cove	117,991	192,575	310,567	62,113	46,585	419,265
12	Briarwood	355,486	0	355,486	71,097	53,323	479,906
13	Comanche Peak North	533,377	0	533,377	106,675	80,006	720,058
13b	Lakecrest Manor, Williamsburg, South Harbor, Nimmo Addition, Rough Creek	66,892	98,784	165,676	33,135	24,851	223,662
14	Live Oak	35,501	48,687	84,188	16,838	12,628	113,654
15	Mesa Grande	97,961	268,693	366,655	73,331	54,998	494,984
16	Laguna Tres	97,096	266,321	363,417	72,683	54,513	490,613
17	Laguna Vista, Whipporwhill Bay	768,620	189,530	958,150	191,630	143,722	1,293,502
18	L'Side Mobile Home Park	597,947	257,119	855,066	171,013	128,260	1,154,340
19	Sky Harbor	304,891	836,273	1,141,164	228,233	171,175	1,540,572
20	North Fork Creek, Bentwater, Mallard Point	972,952	103,698	1,076,650	215,330	161,498	1,453,478
21	Hideaway Bay	111,904	102,312	214,216	42,843	32,132	289,192
23	Nolan Creek	329,299	0	329,299	65,860	49,395	444,553
24	Wood Creek	155,510	0	155,510	31,102	23,326	209,938
25	Western Hills Harbor	1,040,215	113,937	1,154,152	230,830	173,123	1,558,105
26	377 Sunset Strip	533,377	0	533,377	106,675	80,006	720,058
27	Eastwood Village	210,512	0	210,512	42,102	31,577	284,191
28	Sunchase Meadows	32,398	0	32,398	6,480	4,860	43,737
29	Sunchase Hills	104,192	0	104,192	20,838	15,629	140,659
30	Sunchase Hills	54,536	0	54,536	10,907	8,180	73,623
31	Royal Oaks	342,873	0	342,873	68,575	51,431	462,879
31b	Enchanted Village	51,846	0	51,846	10,369	7,777	69,992
32	Walnut Creek	224,270	0	224,270	44,854	33,640	302,764
33	Acton Meadows	150,358	0	150,358	30,072	22,554	202,983
34	Victorian Place	214,683	0	214,683	42,937	32,202	289,822
35	Montego Bay	218,984	82,462	301,447	60,289	45,217	406,953
36	Sandy Beach	101,948	139,814	241,762	48,352	36,264	326,379
37	Rancho Brazos	343,842	0	343,842	68,768	51,576	464,187
38	Jackson Heights	67,727	193,917	261,643	52,329	39,247	353,219
39	Blue Water Shores	44,017	72,550	116,568	23,314	17,485	157,366
40	River Run	360,119	13,256	373,375	74,675	56,006	504,056
41	Oak Hill	198,493	0	198,493	39,699	29,774	267,965
42	Oak Trail Shores	2,582,038	283,380	2,865,418	573,084	429,813	3,868,315
43	Arrowhead Shores	406,693	269,865	676,557	135,311	101,484	913,352
44	Lake Granbury Harbors	426,862	0	426,862	85,372	64,029	576,264
45	Rolling Hills Shores	151,569	108,348	259,917	51,983	38,988	350,888
99	Ports O'Call	0	136,754	136,754	27,351	20,513	184,618
							\$28,210,048

Appendix C
Texas Water Development Board
Comments on Draft Report



TEXAS WATER DEVELOPMENT BOARD

William B. Madden, *Chairman*
Jack Hunt, *Member*
Wales H. Madden, Jr., *Member*

Craig D. Pedersen
Executive Administrator

Noé Fernández, *Vice-Chairman*
William W. Meadows, *Member*
Kathleen Hartnett White, *Member*

October 19, 2000

RECEIVED

OCT 27 2000

GENERAL MANAGER

Mr. Gary Gwyn
General Manager
Brazos River Authority
P.O. Box 7555
Waco, Texas 76714-7555

Re: Regional Facility Planning Contract Between the Brazos River Authority (BRA) and the Texas Water Development Board (Board), TWDB Contract No. 99-483-313, Review Comments on Draft Final Report "Hood County Regional Sewerage System"

Dear Mr. Gwyn:

Staff members of the Texas Water Development Board have completed a review of the draft report under TWDB Contract No. 99-483-313 and offer comments shown in Attachment 1.

However, Part A in Attachment 1 was not included or addressed in the Draft Final Report and as submitted does not meet contractual requirements. Therefore, please submit these items for review prior to delivery of the Final Report.

After review comments have been transmitted to BRA regarding the above referenced items, BRA will consider incorporating all comments from the EXECUTIVE ADMINISTRATOR and other commentors on the draft final report into the Final Report.

Please contact Mr. David Meeseey, the Board's designated Contract Manager, at (512) 936-0852, if you have any questions about the Board's comments.

Sincerely:

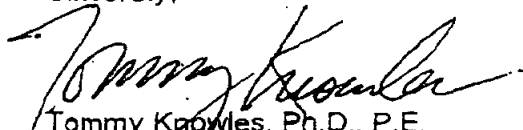
Tommy Knowles, Ph.D., P.E.
Deputy Executive Administrator
Office of Planning

Attachment

Cc: David Meeseey

Our Mission

Provide leadership, technical services and financial assistance to support planning, conservation, and responsible development of water for Texas.

P.O. Box 13231 • 1700 N. Congress Avenue • Austin, Texas 78711-3231

Telephone (512) 463-7847 • Telefax (512) 475-2053 • 1-800- RELAY TX (for the hearing impaired)

URL Address: <http://www.twdb.state.tx.us> • E-Mail Address: info@twdb.state.tx.us

Printed on Recycled Paper

	<u>Granbury</u>	<u>Hood County</u>
TWDB projection, 2000	8,281	41,615
TSDC estimate, 1-1-2000	6,403	36,426
NCTCOG estimate, 1-1-2000	6,850	40,750

The current population estimates from both of these well-regarded organizations are less than the TWDB projection for 2000. Justification for the use of the higher set of population projections is not supported.

Additionally, the TWDB projections cited in the study as being inadequate were approved by the Brazos G, SB1 regional water planning group. Use of projections other than these requires coordination with TWDB and the regional planning group as stated in SOW, Item II. It is recommended that future feasibility or design studies continue to monitor population trends closely and to coordinate with the Brazos G Regional Water Planning Group.

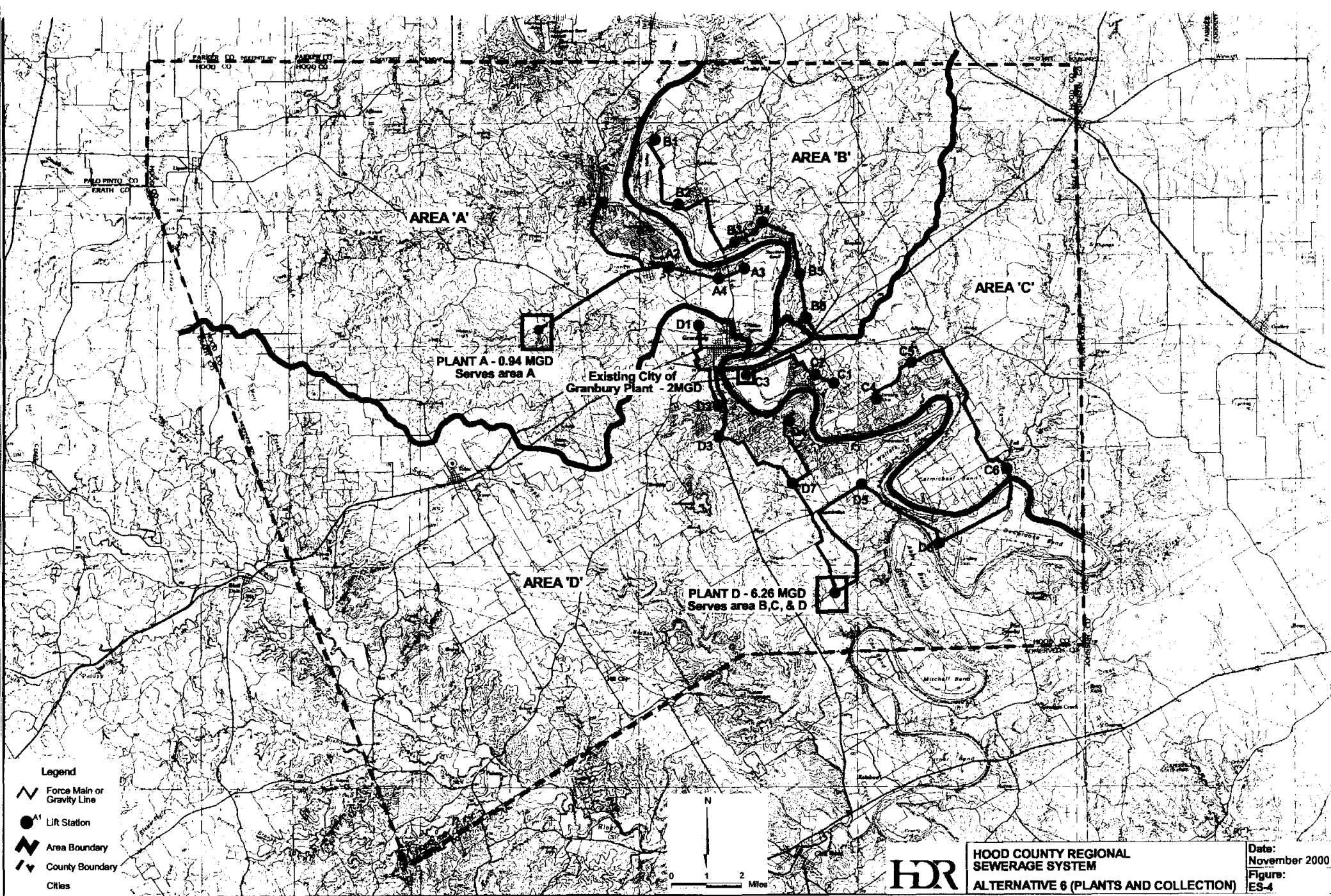

**ATTACHMENT 1
TEXAS WATER DEVELOPMENT BOARD**

**Review comments for: Hood County Regional Sewerage System
Contract No. 99-483-313**

A. The following items should be addressed as required in the Scope of Work:

1. The report does not provide wastewater flow projections through the year 2030 as called for in the Scope of Work (SOW), Item II. Projections in the report are only provided through 2020. Please include projections through 2030.
2. County wide population projections through 2050 were not included as called for in Scope of Work, Item II. Please include these projections in the report.

B. The following comments are offered for consideration:

1. Page xvi of the Executive Summary shows the cost table for the alternatives. Alternative 6 is stated to be similar to Alternative 5 except for adjustments shown at the bottom of the page. Note that engineering costs as a percentage of the project construction costs normally increase for projects of lesser costs rather than drop as indicated in the footnote.
2. It is recommended that the Hood County Intergovernmental Committee charge its Water and Wastewater Subcommittee or another body with the task of determining the feasibility and local desire to implement any or all of the study recommendations.
3. This study includes two sets of population projections, the TWDB projections approved for SB1 planning and "a higher population projection based on local input." (Executive Summary, page x)

	<u>2000</u>	<u>2010</u>	<u>2020</u>
Hood County – High	59,231	89,660	120,000
Hood County – SB1	41,615	53,504	67,659
Granbury – High	11,804	24,815	41,889
Granbury – SB1	8,281	14,808	23,618

The "high" projections are 42% greater than TWDB projections in 2000, 68% greater in 2010, and 77% greater in 2020.

The justification for the set of high projections is that "Some in Hood County have expressed concern that the SB1 forecasts are too low and that the current population already exceeds the SB1 year 2000 forecast." (page 2-4). The Texas State Data Center (TSDC) and the North Central Texas Council of Governments (NCTCOG) have recently published estimates of the population in Granbury and Hood County as of January 1, 2000:

	<u>Granbury</u>	<u>Hood County</u>
TWDB projection, 2000	8,281	41,615
TSDC estimate, 1-1-2000	6,403	36,426
NCTCOG estimate, 1-1-2000	6,850	40,750

The current population estimates from both of these well-regarded organizations are less than the TWDB projection for 2000. Justification for the use of the higher set of population projections is not supported.

Additionally, the TWDB projections cited in the study as being inadequate were approved by the Brazos G, SB1 regional water planning group. Use of projections other than these requires coordination with TWDB and the regional planning group as stated in SOW, Item II. It is recommended that future feasibility or design studies continue to monitor population trends closely and to coordinate with the Brazos G Regional Water Planning Group.

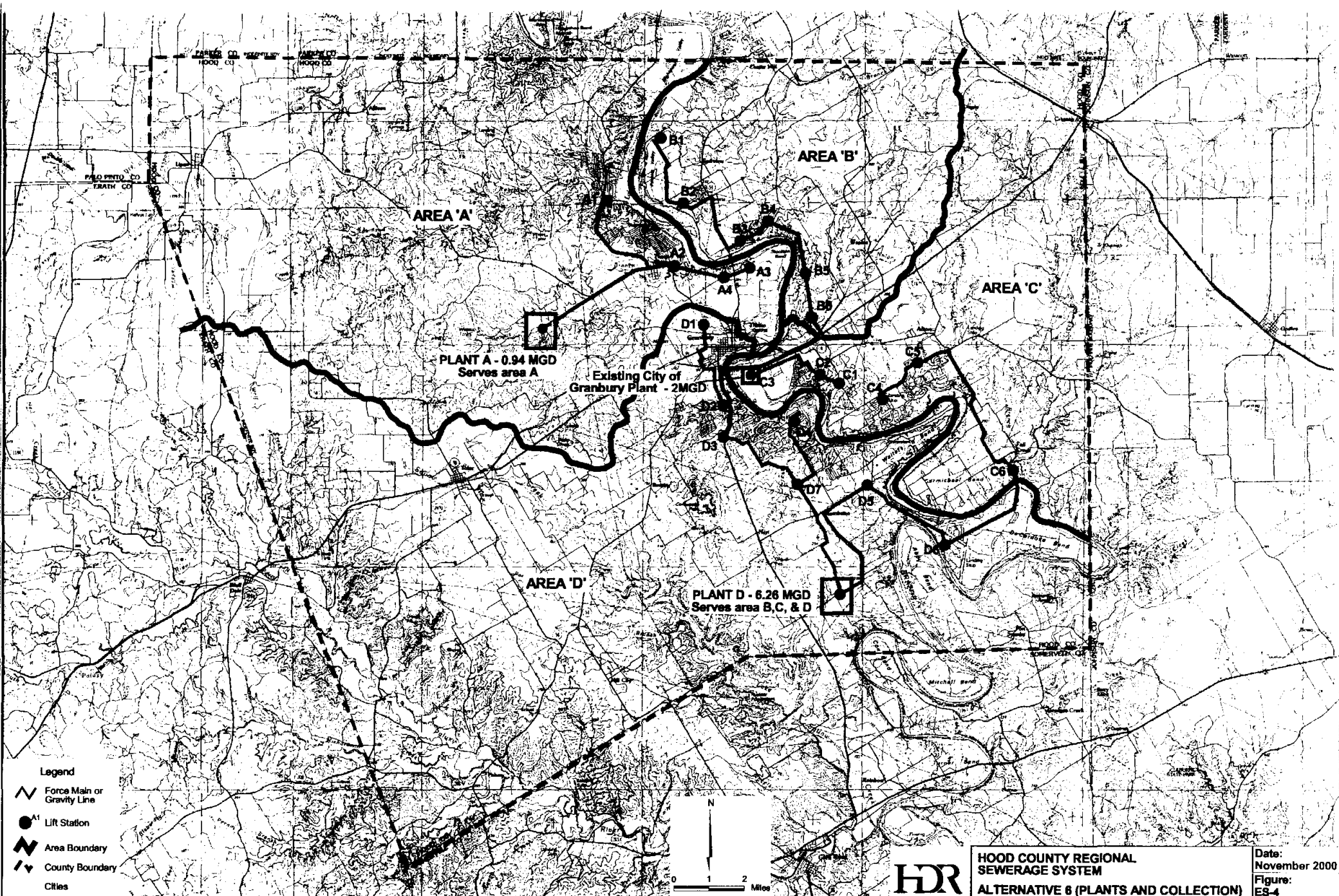

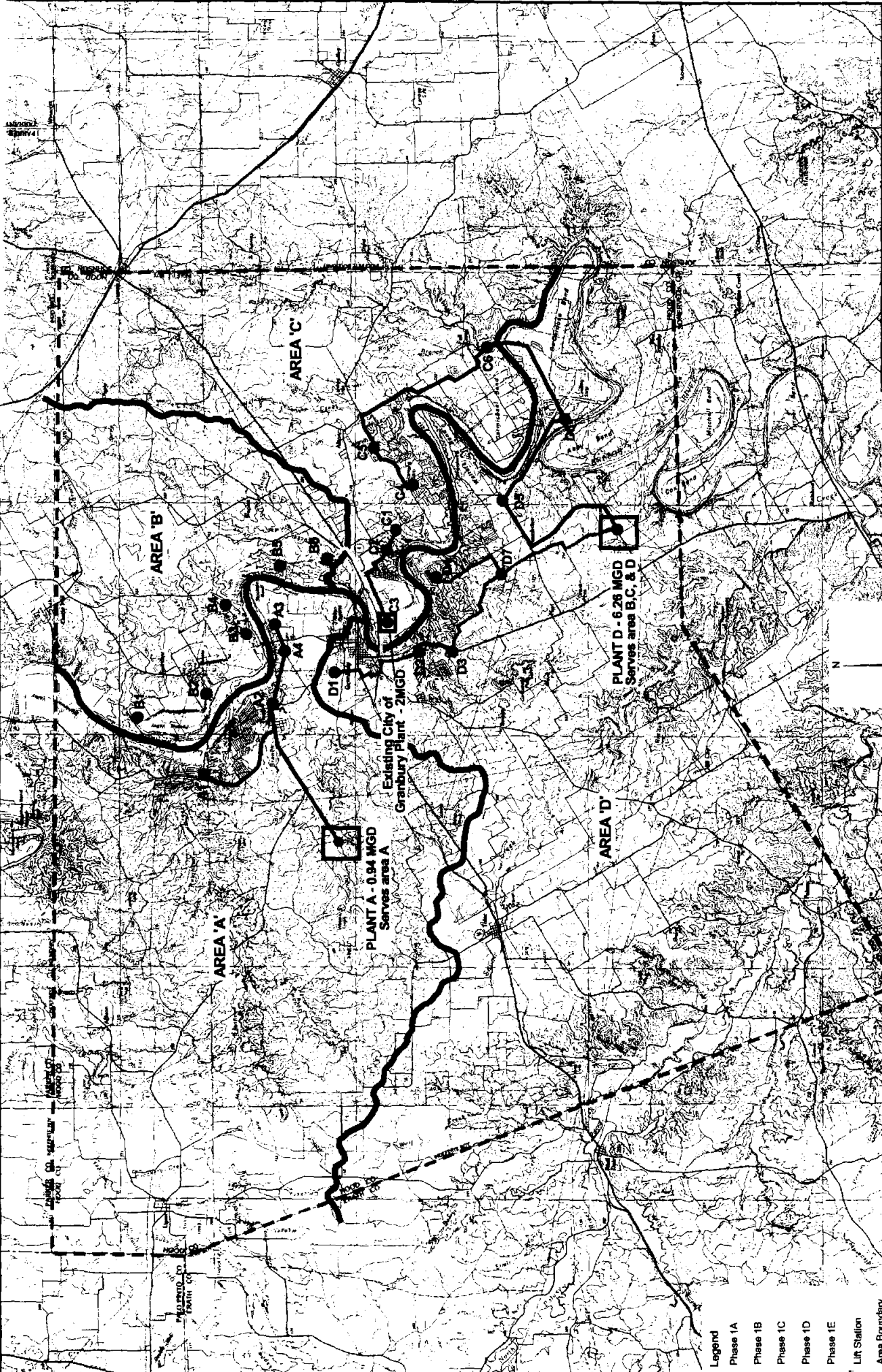

Legend

- Phase 1A
- Phase 1B
- Phase 1C
- Phase 1D
- Phase 1E
- Lift Station
- Area Boundary
- County Boundary
- Cities

PLANT A - 0.94 MGD
Serves area A

PLANT B - 0.94 MGD
Serves area B

Existing City of Granbury Plant - 2MGD
Serves area C

PLANT D - 6.26 MGD
Serves area B, C, & D

AREA 'A'

AREA 'B'

AREA 'C'

AREA 'D'

HOOD COUNTY REGIONAL SEWERAGE SYSTEM
ALTERNATIVE 6 (PHASING PLAN)

HDR

Date: November 2000
Figure: ES-5

0 2 Miles

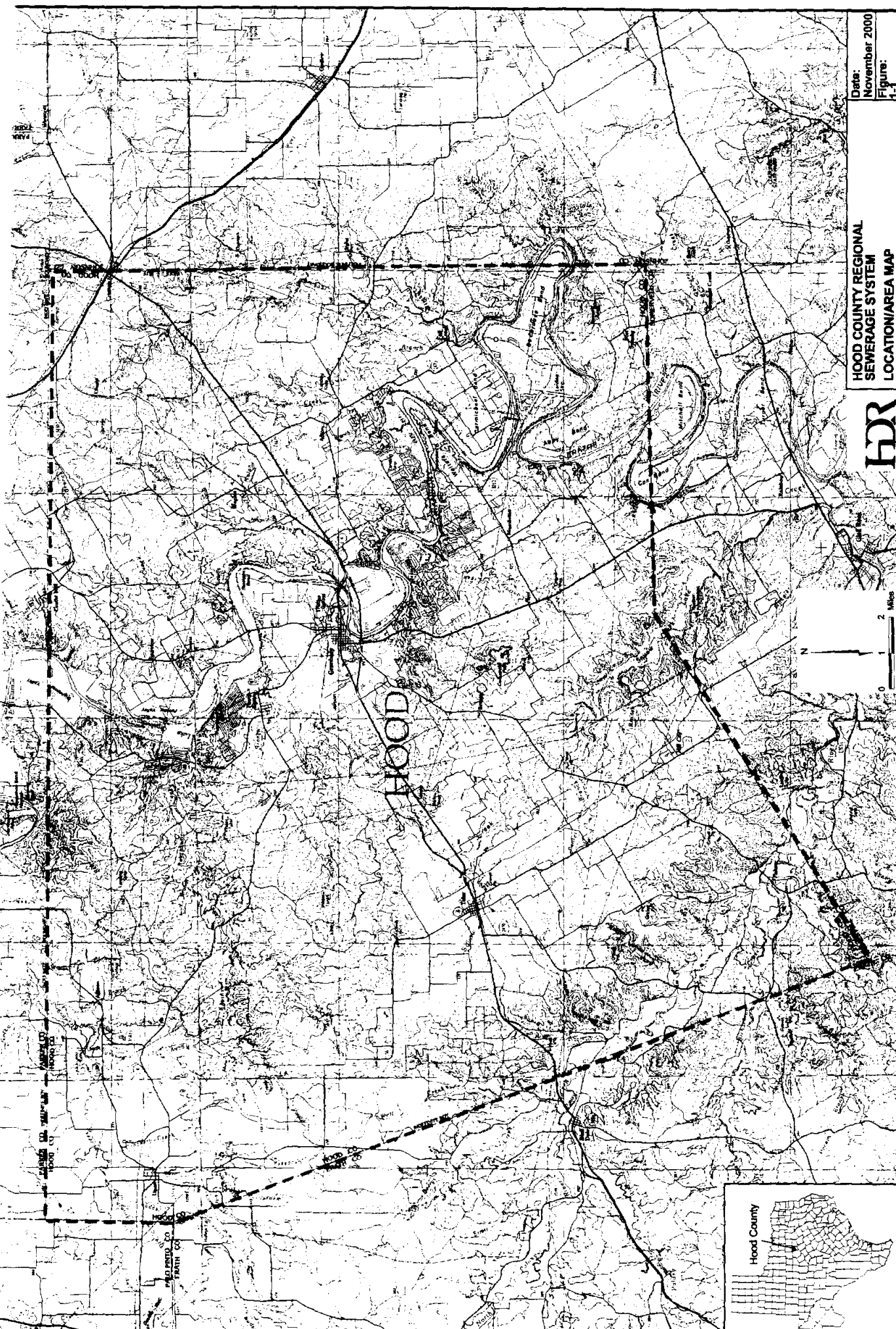

Date: November 2000
Figure: 1-1

**HOOD COUNTY REGIONAL
SEWERAGE SYSTEM
LOCATION/AREA MAP**

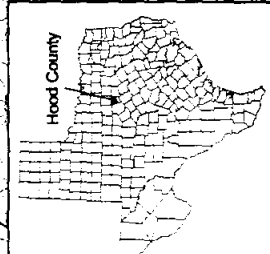
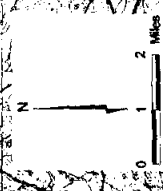

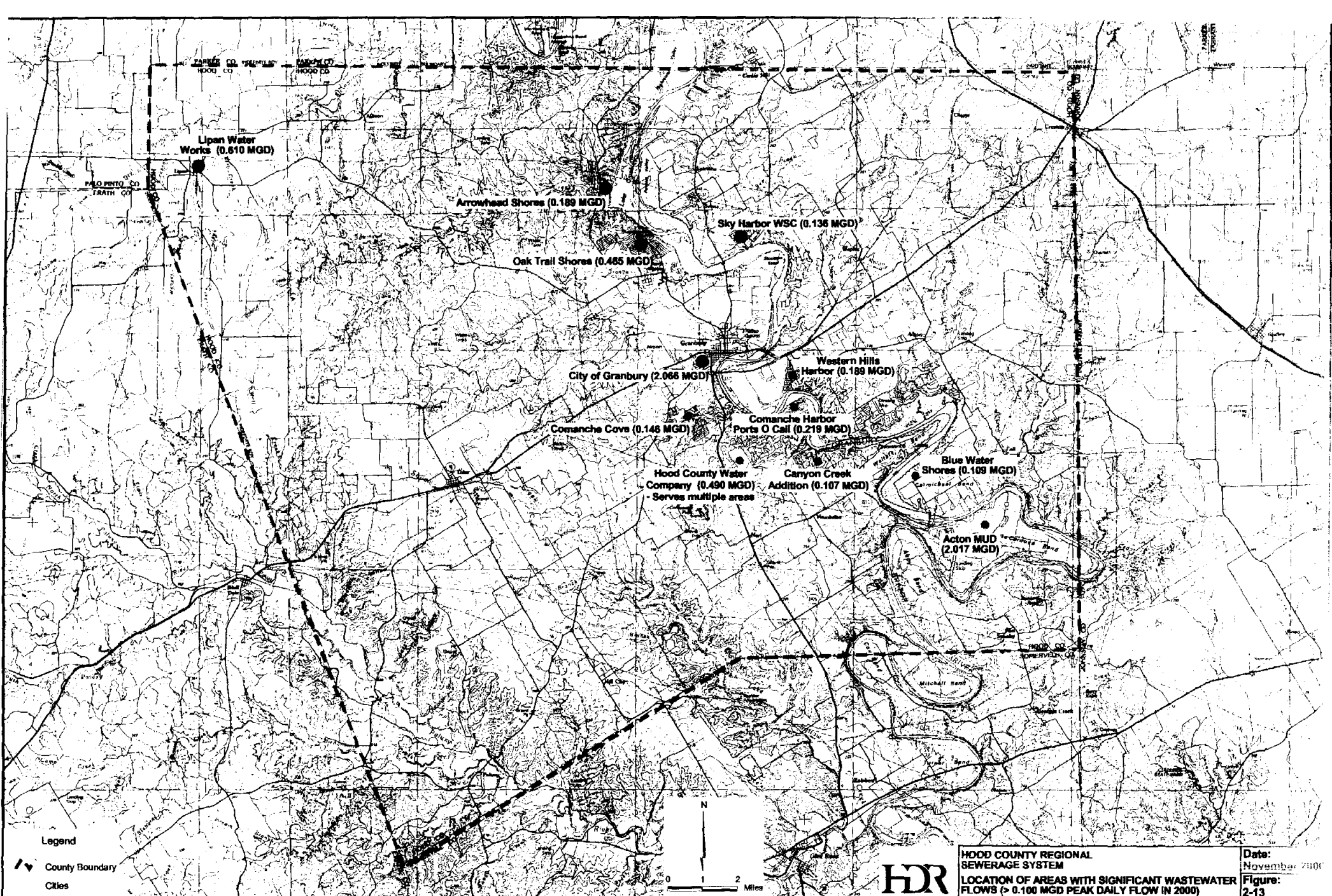

Legend
 County Boundary
 Cities

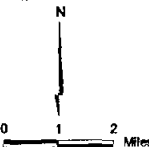

HDR

HOOD COUNTY REGIONAL SEWERAGE SYSTEM
LOCATION OF AREAS WITH SIGNIFICANT WASTEWATER FLOWS (> 0.100 MGD PEAK DAILY FLOW IN 2000)

Date: November 2000
 Figure: 2-13

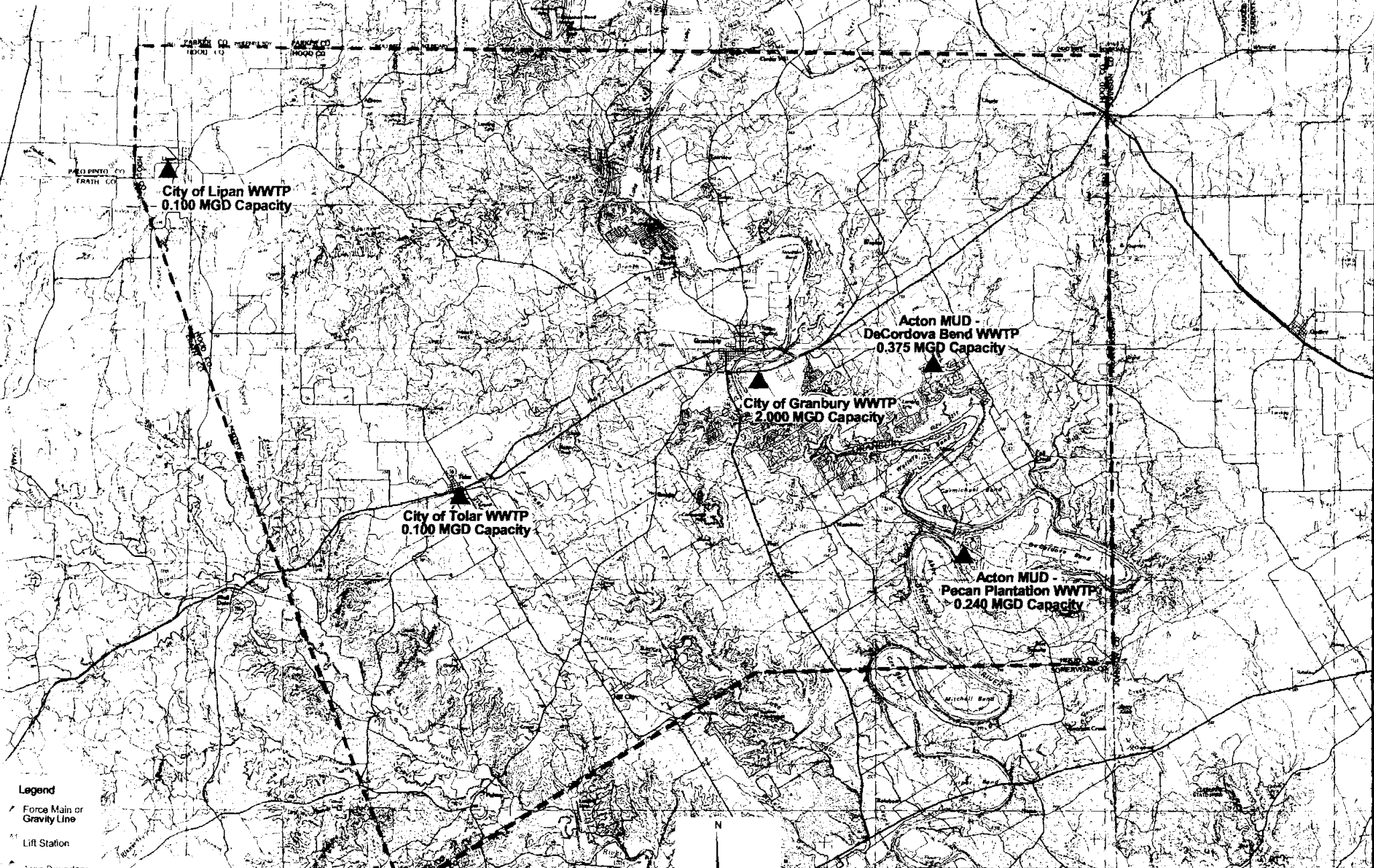

- Legend**
- Force Main or Gravity Line
 - Lift Station
 - Area Boundary
 - County Boundary
 - Cities

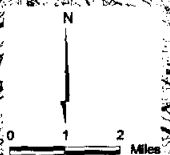

HDR HOOD COUNTY REGIONAL SEWERAGE SYSTEM
EXISTING WASTEWATER TREATMENT FACILITIES

Date: November 2000
 Figure: 3-1

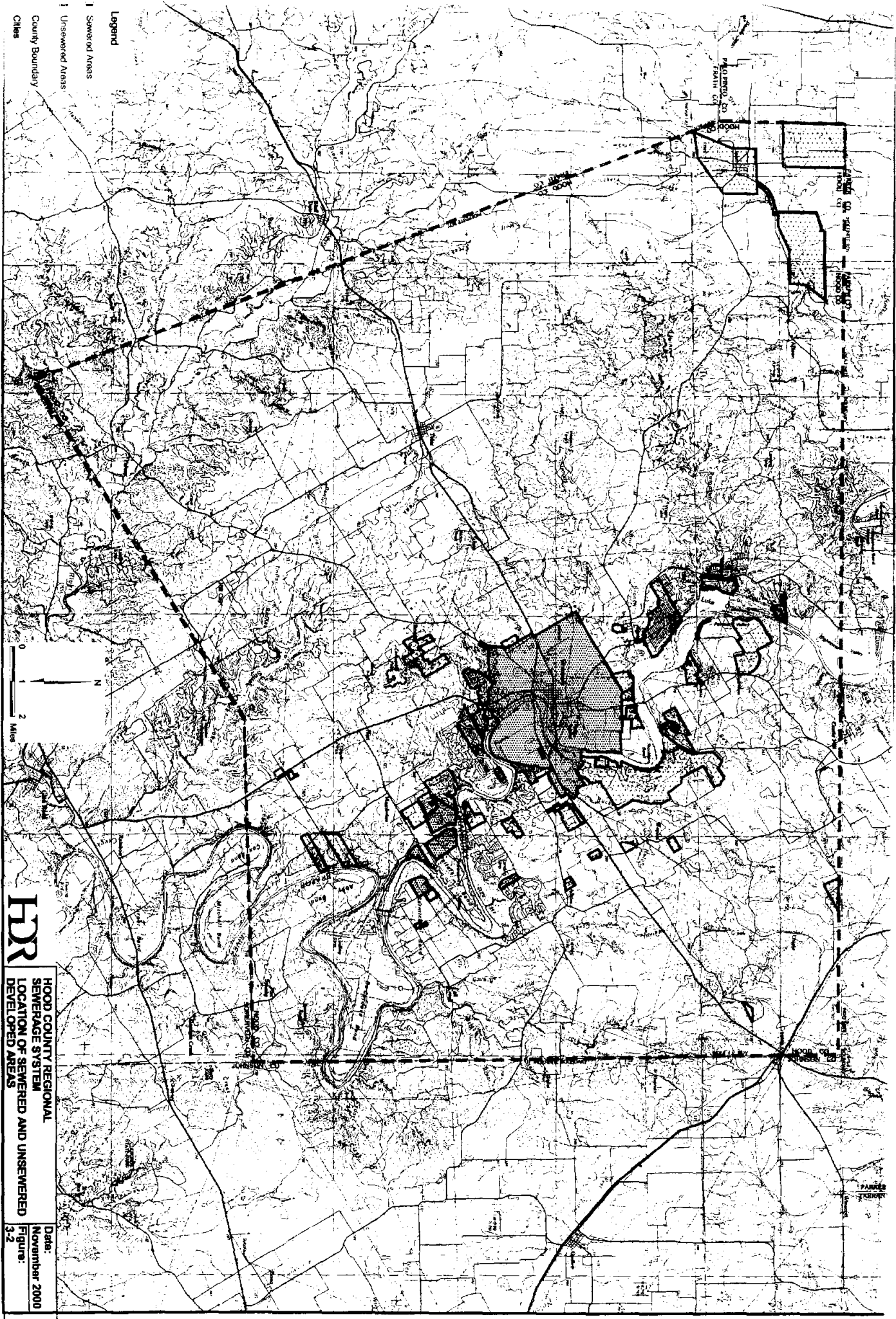

- Legend**
- 1 Sewered Areas
 - 1 Unsewered Areas

County Boundary
Cities



HR

**HOOD COUNTY REGIONAL
SEWERAGE SYSTEM
LOCATION OF SEWERED AND UNSEWERED
DEVELOPED AREAS**

Date:
November 2000
Figure:
3-2

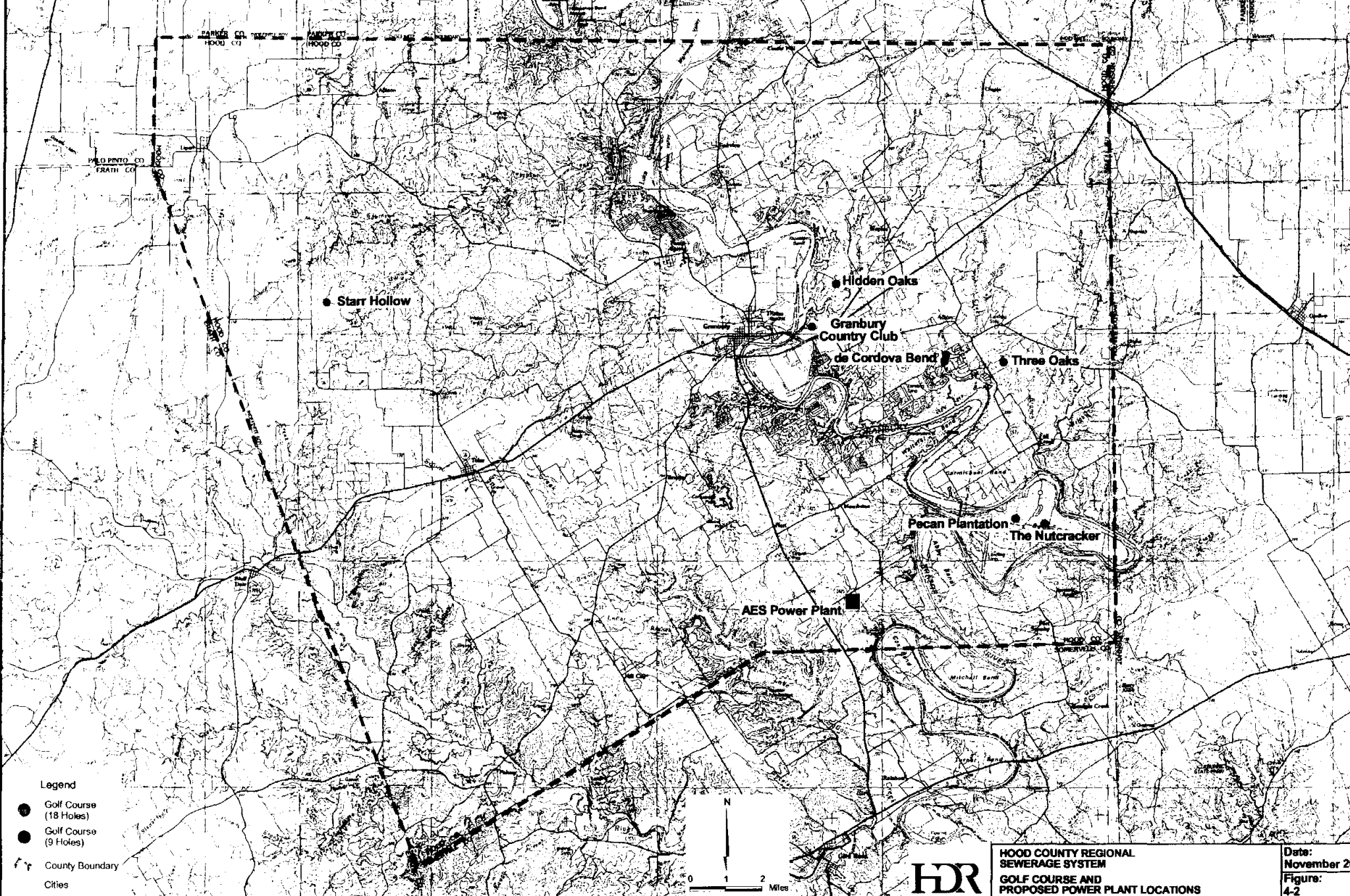

Legend

- Golf Course (18 Holes)
- Golf Course (9 Holes)
- County Boundary
- Cities

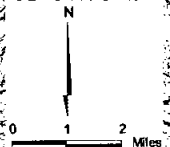

**HOOD COUNTY REGIONAL
SEWERAGE SYSTEM
GOLF COURSE AND
PROPOSED POWER PLANT LOCATIONS**

Date: November 2011
Figure: 4-2

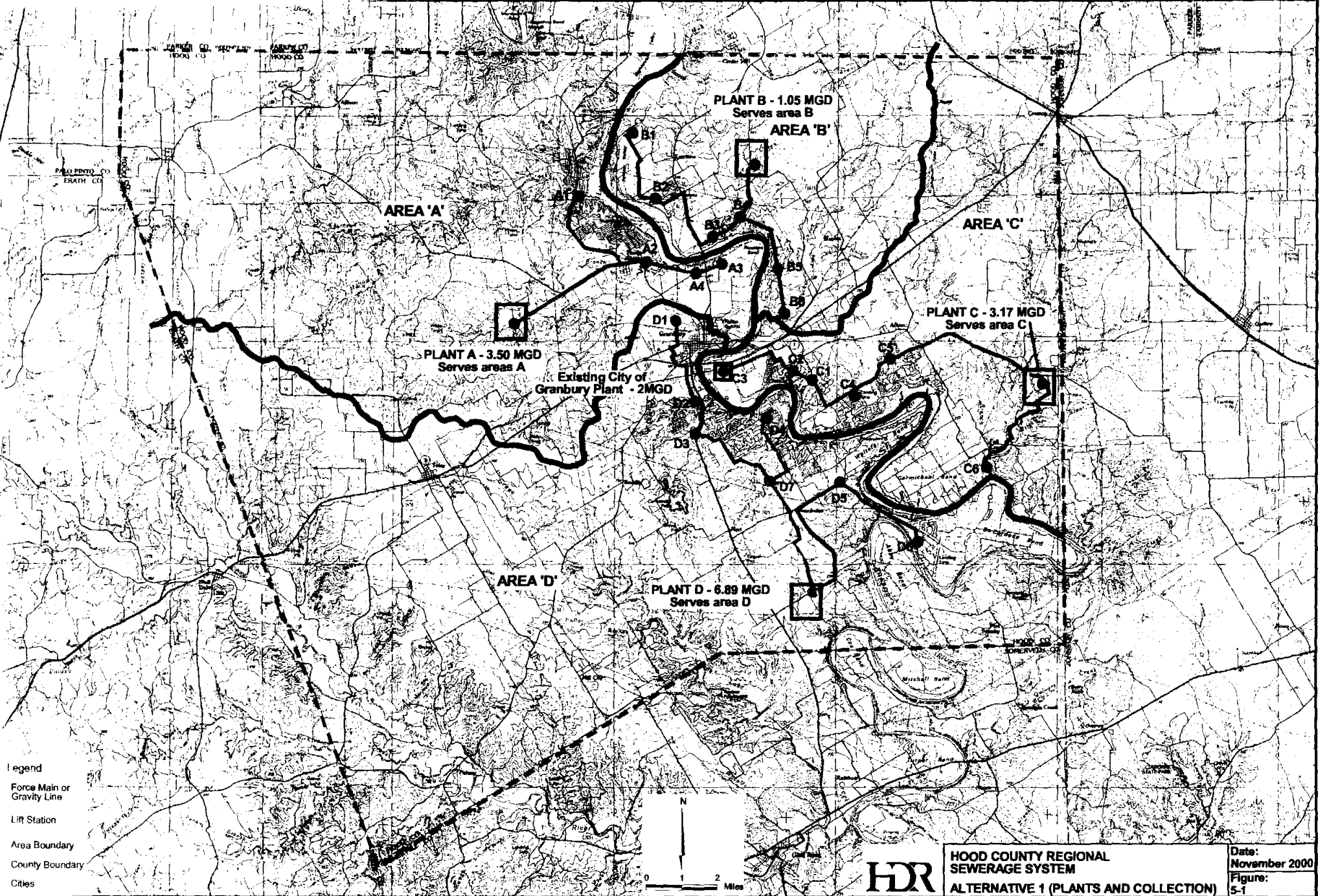

Egrind
 Force Main or
 Gravity Line
 Lift Station
 Area Boundary
 County Boundary
 (7/99)

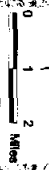
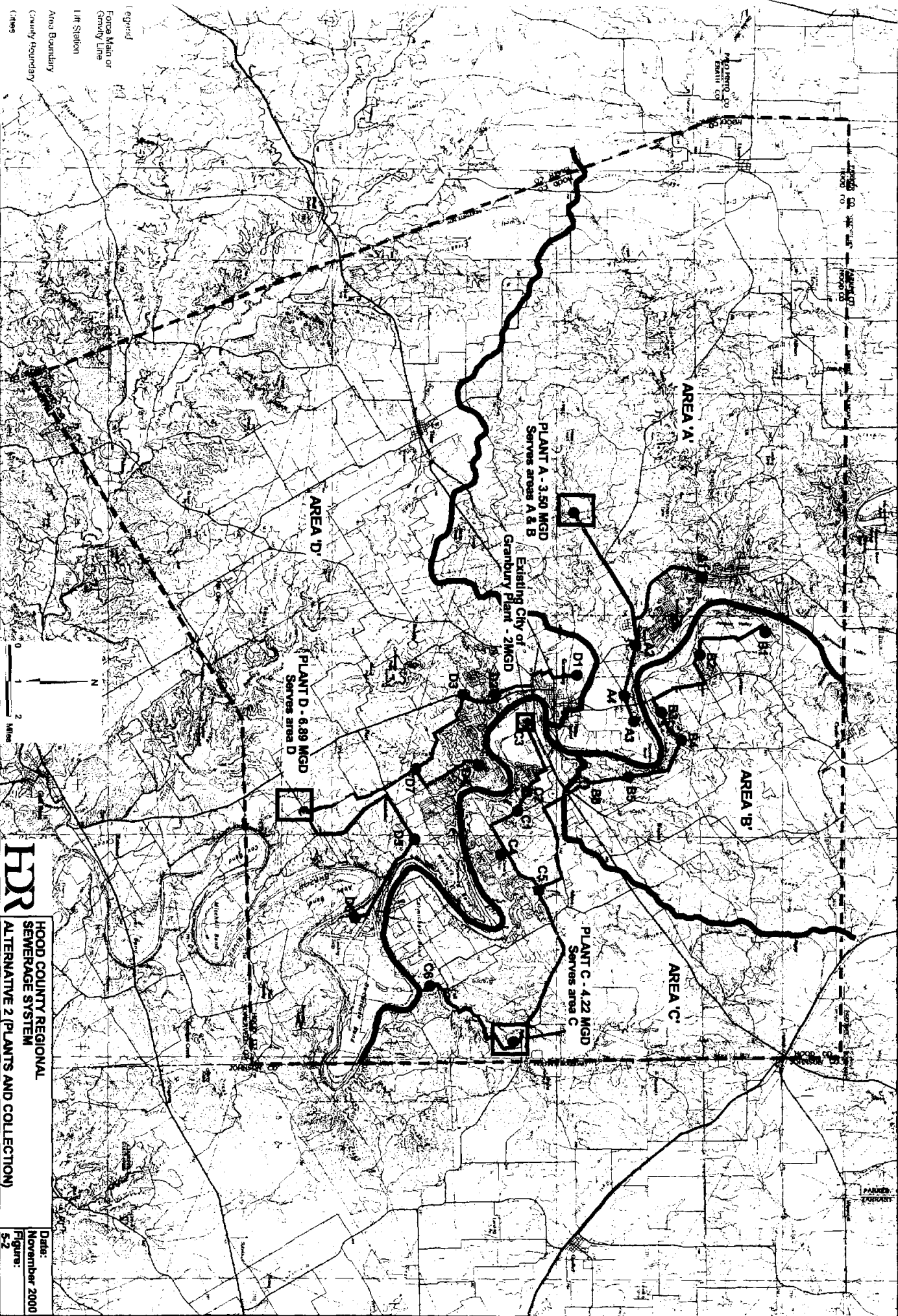

HRR

**HOOD COUNTY REGIONAL
 SEWERAGE SYSTEM
 ALTERNATIVE 2 (PLANTS AND COLLECTION)**

Date: November 2000
 Figure: S-2

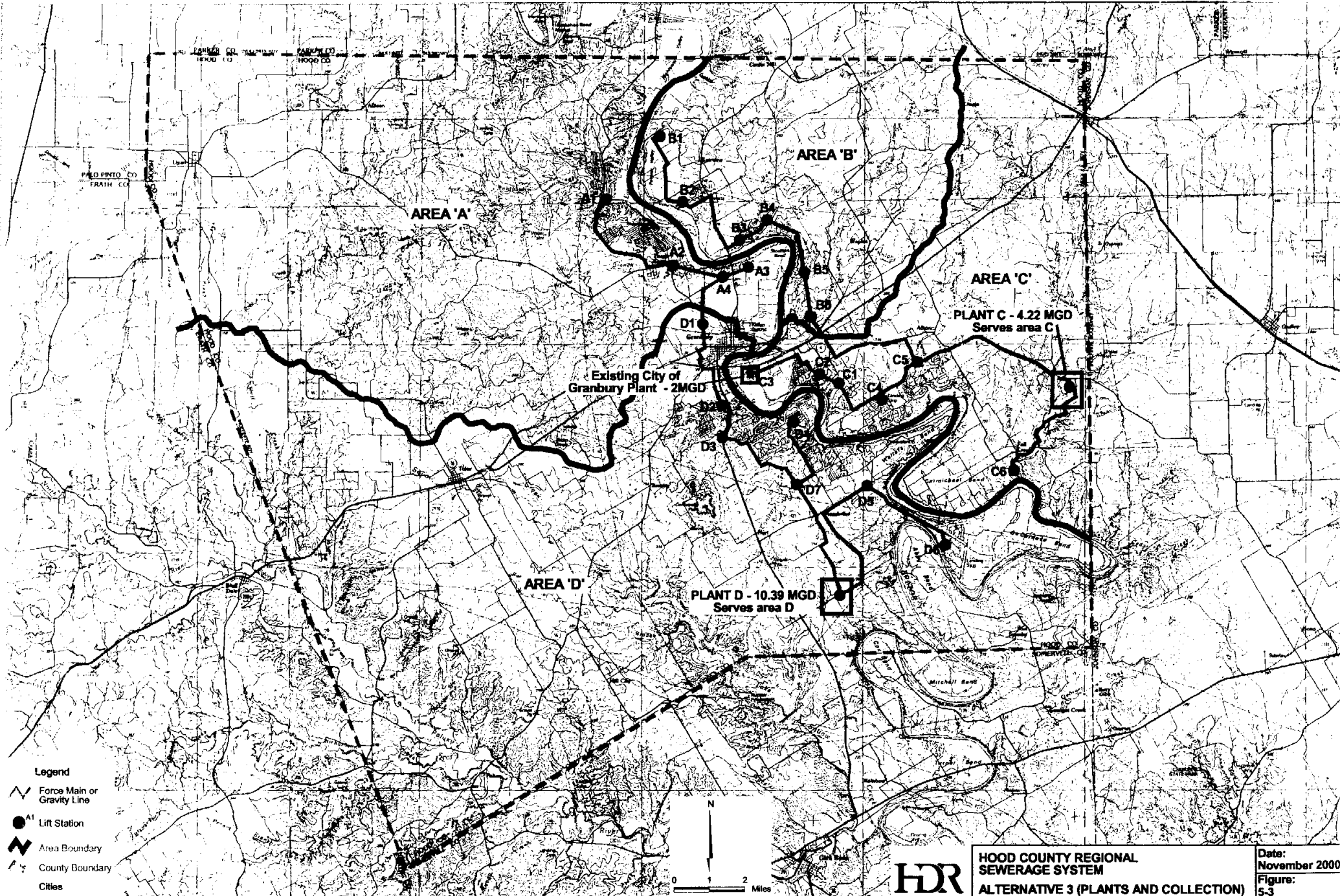

- Legend**
- Force Main or Gravity Line
 - Lift Station
 - Area Boundary
 - County Boundary
 - Cities

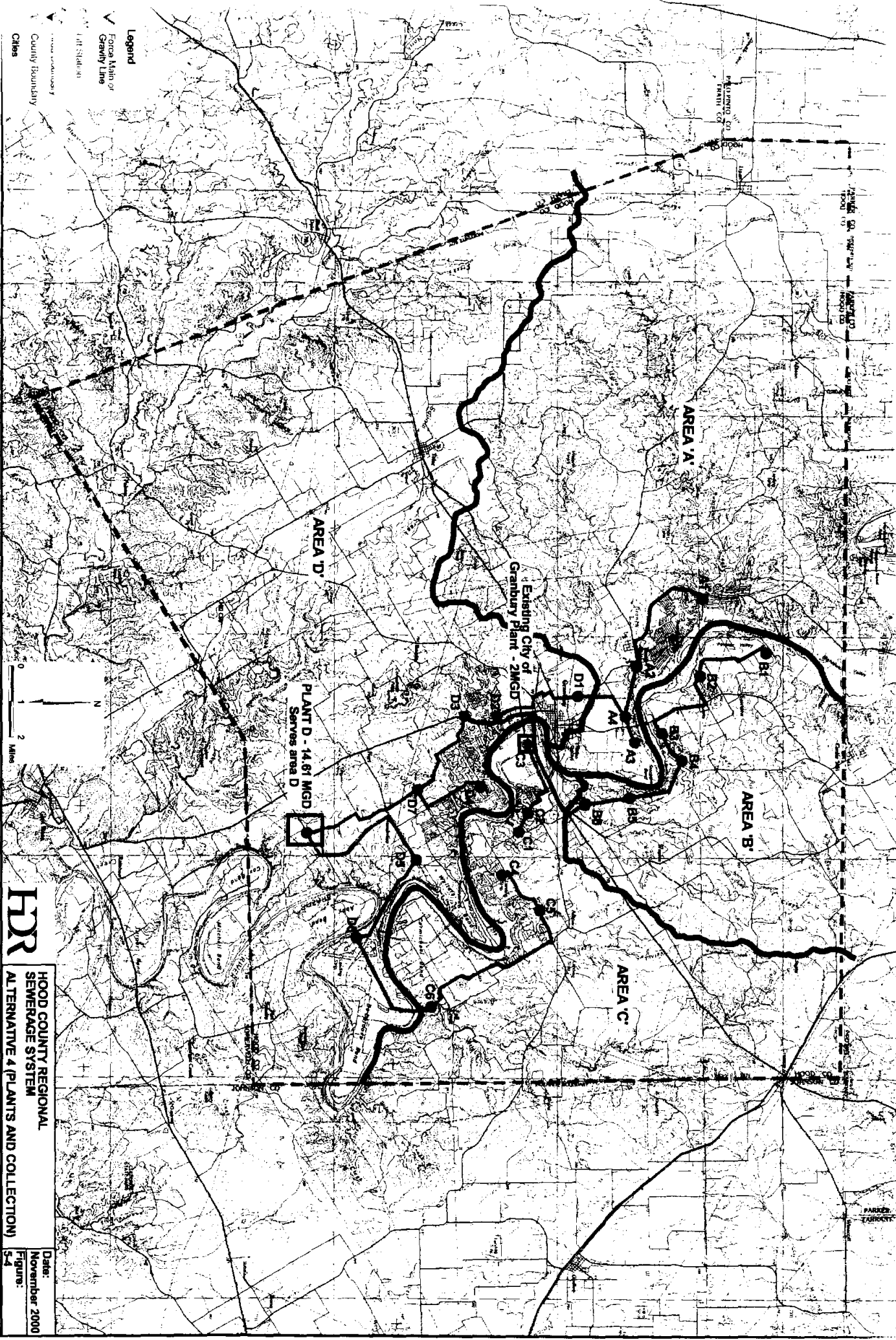

HR

HOOD COUNTY REGIONAL SEWERAGE SYSTEM ALTERNATIVE 4 (PLANTS AND COLLECTION)

Date: November 2000
 Figure: 5-4

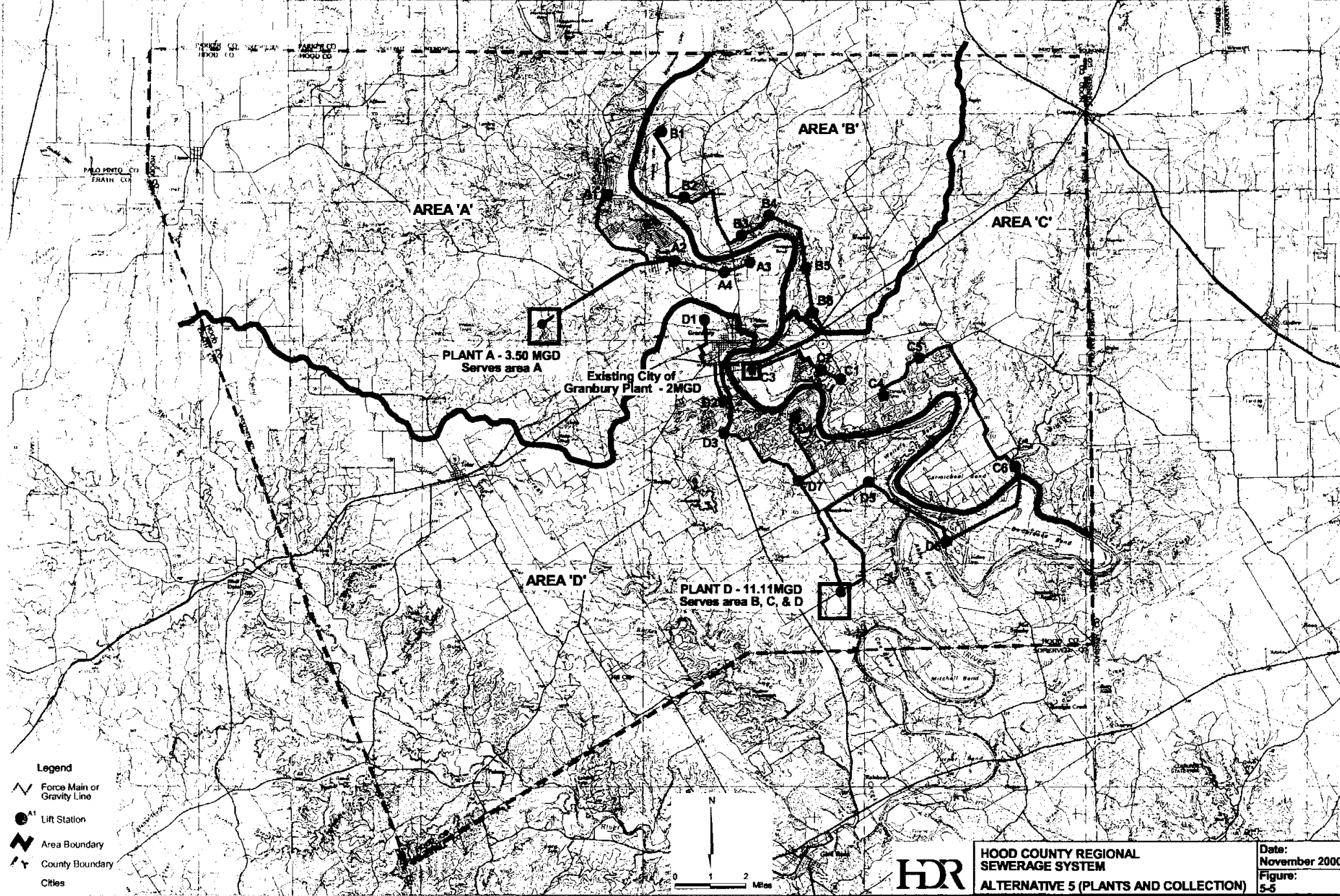

- Legend**
- Force Main or Gravity Line
 - Lift Station
 - Area Boundary
 - County Boundary
 - Cities

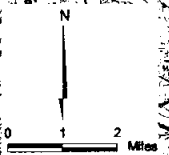

HOOD COUNTY REGIONAL SEWERAGE SYSTEM
ALTERNATIVE 5 (PLANTS AND COLLECTION)

Date: November 2000
 Figure: 5-5

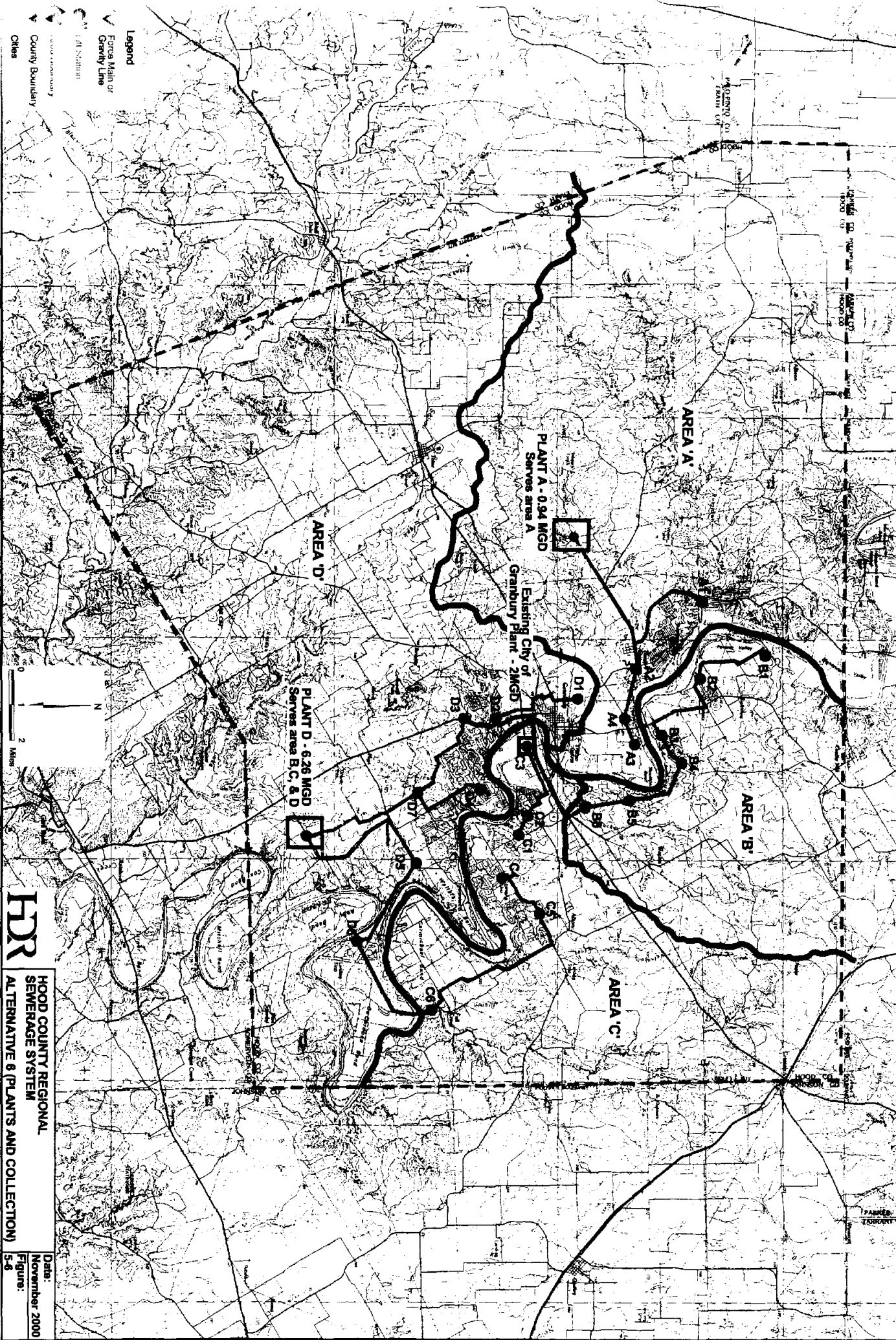

HDR

HOOD COUNTY REGIONAL SEWERAGE SYSTEM ALTERNATIVE 6 (PLANTS AND COLLECTION)

Date: November 2000
 Figure: 5-6

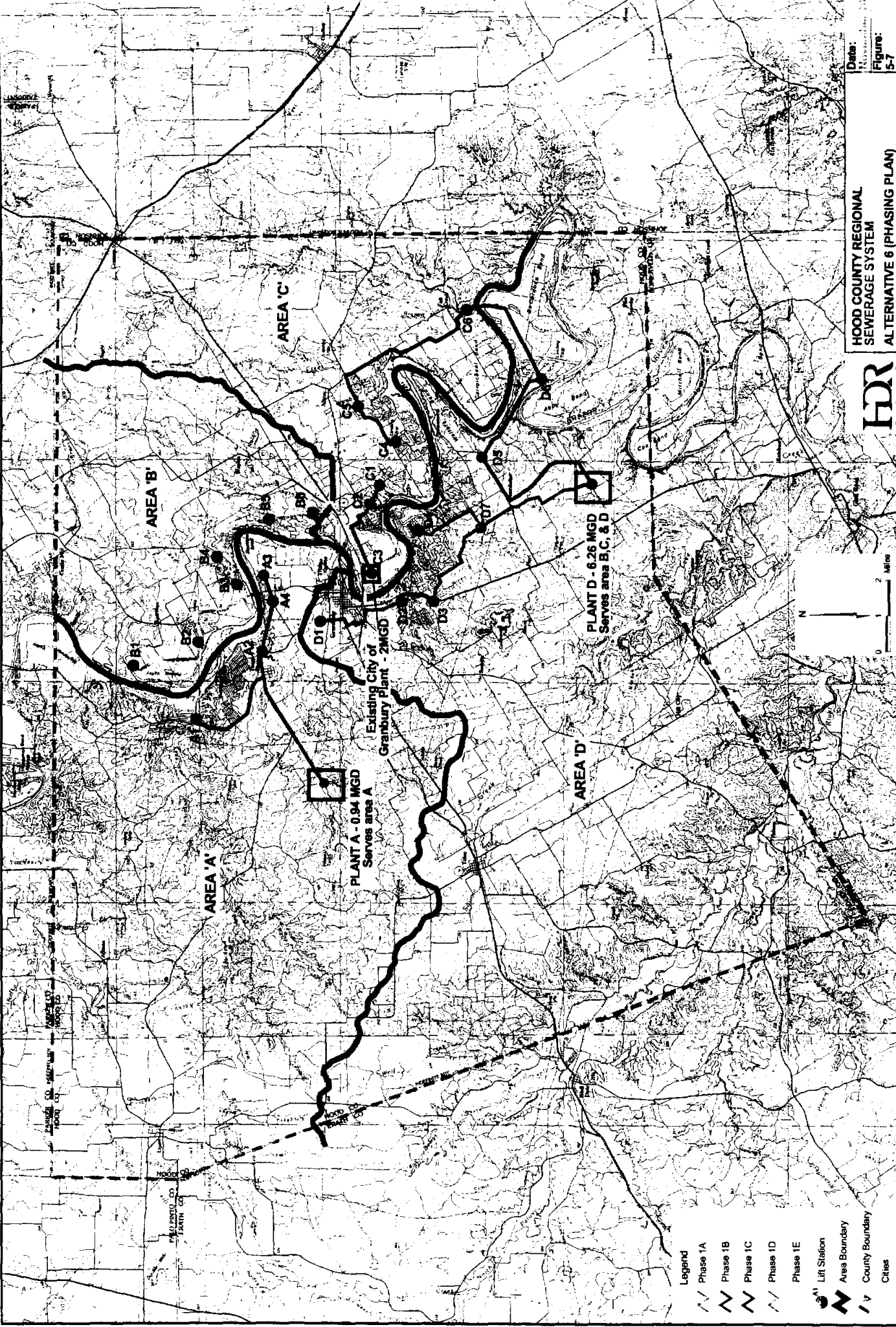

HOOD COUNTY REGIONAL
SEWERAGE SYSTEM
ALTERNATIVE 6 (PHASING PLAN)



Date: 11/15/2011
Figure: 5-7

- Legend
- Phase 1A
 - Phase 1B
 - Phase 1C
 - Phase 1D
 - Phase 1E
 - Lift Station
 - Area Boundary
 - County Boundary
 - Cities

PLANT A - 0.94 MGD
Serves area A

Existing City of
Granbury Plant - 2MGD

PLANT D - 6.26 MGD
Serves area B, C, & D

AREA 'A'

AREA 'B'

AREA 'C'

AREA 'D'

Map labels include: AREA 'A', AREA 'B', AREA 'C', AREA 'D', PLANT A - 0.94 MGD Serves area A, Existing City of Granbury Plant - 2MGD, PLANT D - 6.26 MGD Serves area B, C, & D, and various street names like STATE ST, W. STATE ST, and S. STATE ST.

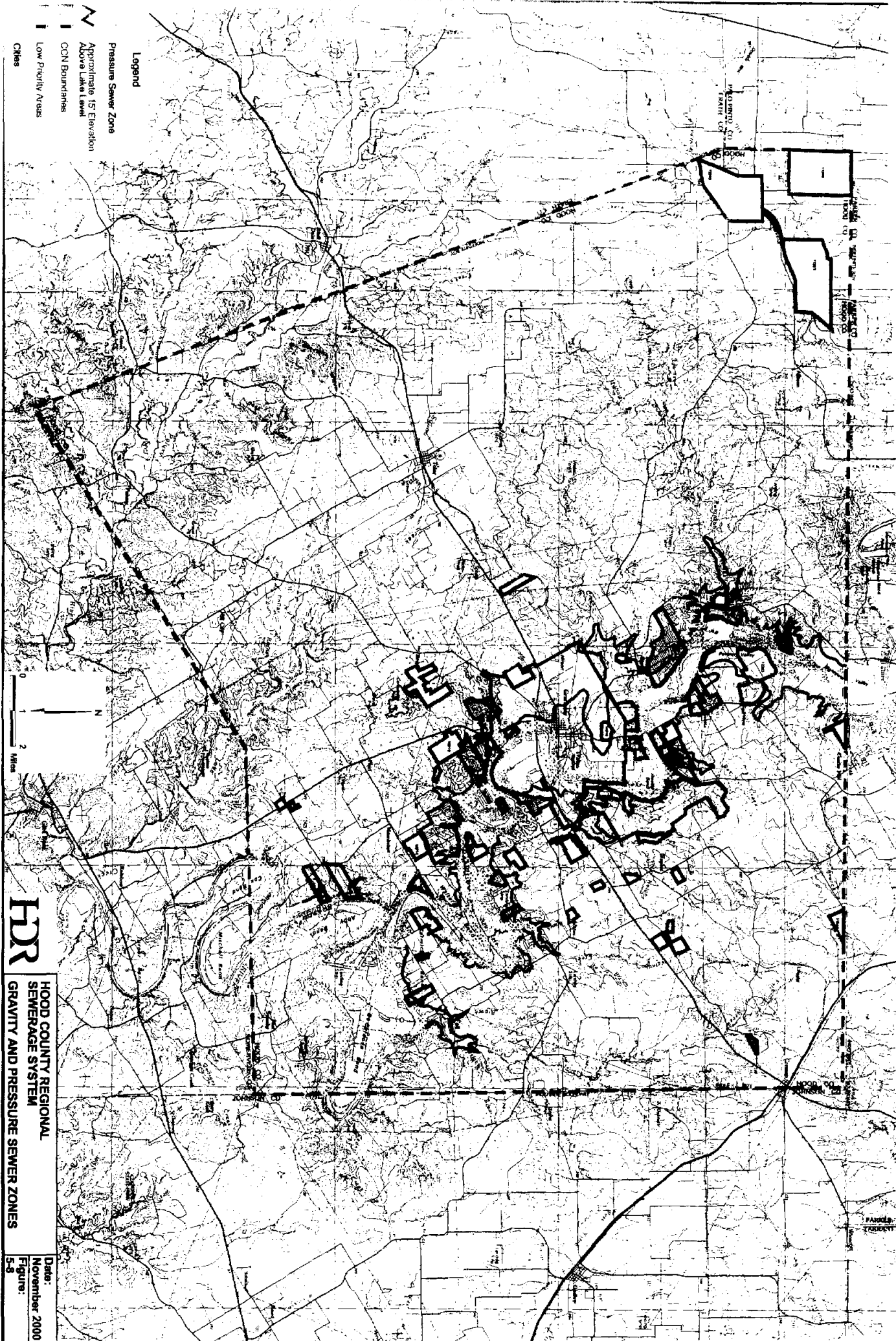

- Legend**
- Pressure Sewer Zone
 - Approximate 15' Elevation Above Lake Level
 - CCN Boundaries
 - Low Priority Areas
 - Other

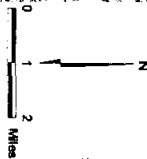

HRR

HOOD COUNTY REGIONAL SEWERAGE SYSTEM GRAVITY AND PRESSURE SEWER ZONES

Date: November 2000
 Figure: 5-8